



# Chapter 3

## INDEX

### A Linear bar grilles:

1. Supply linear bar grille.....	ASLG .....	3.1
2. Supply linear bar register.....	ASLR .....	3.2
3. Return linear bar grille.....	ARLG.....	3.3
4. Return linear bar register.....	ARLR.....	3.4
5. Supply curved linear bar grille .....	ASLG (C).....	3.5
6. Supply linear bar register (sleek)....	ASLR (S).....	3.6
• Standard finishes.....		3.7
• Mitered corners.....		3.7
• Bar deflection.....		3.8
• Accessories.....		3.9
• End Flanges.....		3.9
• Fixing details.....		3.10
• standard sizes.....		3.11
• How to order .....		3.11

### B Air flow data (bar spacing 12mm)

1. Supply air register 15°-2 way .....	Tab: 3.1.....	3.12
2. Supply air register 15°-1 way .....	Tab: 3.2.....	3.13
3. Supply air register 0° .....	Tab: 3.3.....	3.14
4. Return air register 15°-2 way.....	Tab: 3.4.....	3.15
5. Return air register 15°-1 way.....	Tab: 3.5.....	3.16
6. Return air register 0° .....	Tab: 3.6.....	3.17
7. Supply air register 15°-2 way (6 mm pitch) :	Tab: 3.7.....	3.18
8. Return air register 15°-2 way (6 mm pitch):.	Tab: 3.8.....	3.19





air master

# Supply air linear bar grille

► Model: ASLG

## Construction:

- **Frame:** High quality extruded aluminium profile with 30 mm flange width as standard. 12, 16, 24 mm flange widths are optional.
- **Face bars:** High quality aluminium profiles of 0°, 15° – 1 way throw and 15° – 2 way throw.
- **Bar spacing:** 12 mm as standard. 6 mm as option.
- **Grille width:** 50 mm to 300 mm with increments of 50 mm.
- **Length:** 1 meter as standard. Available from 0.2 mt to 5.8 mt in a single piece.

## Description:

- Frame and face bars are of high quality extruded aluminium profiled construction with the advantages of corrosion resistance and rigidity.
- Horizontal face bars with 0°, 15° – 1 way throw and 15° – 2 way throw are fixed rigidly to the frame with 8-mm pipes.
- Vertical aluminium aerofoil blades are fixed at the rear side of the frame by nylon bushes. These blades can be adjusted manually and individually in the vertical plane to obtain optimum air distribution.
- For perfect unbroken appearance of continuous runs, alignment strips are provided with no additional cost.



- Total structure is manufactured by mechanical assembly, assuring rigidity and to maintain straight-line appearance.
- Foam gasket is sealed around the back of the frame as option to avoid air leakage.
- Supplied with C - clamps for concealed fixing.

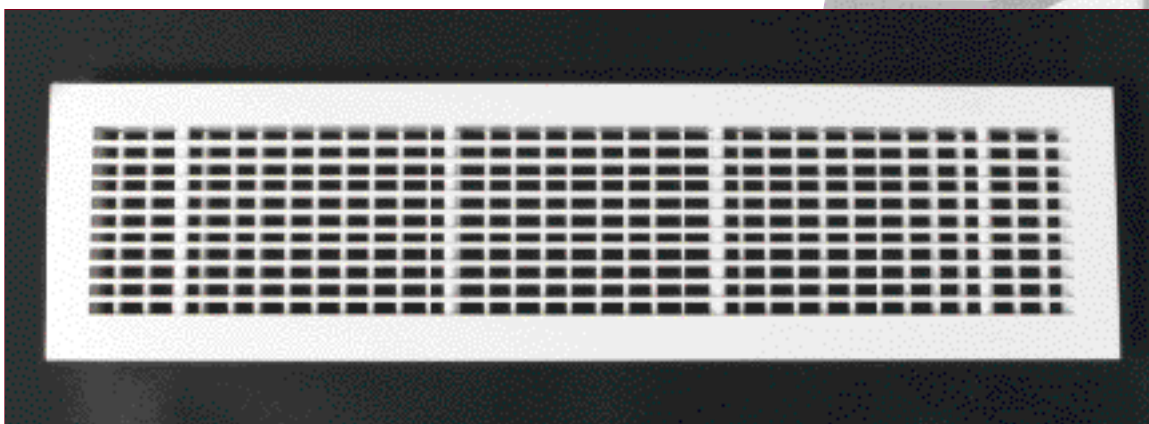
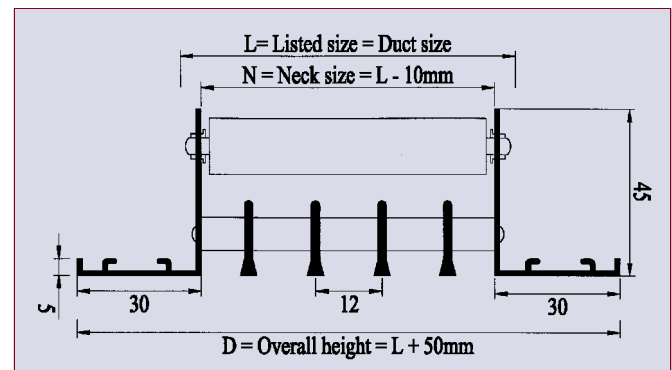



air master

# Supply air linear bar register

Model: ASLR

## Construction:

- **Frame:** High quality extruded aluminium profile with 30 mm flange width as standard. 12, 16, 24 mm flange widths are optional.
- **Face bars:** High quality aluminium profiles of 0°, 15° – 1 way throw and 15° – 2 way throw.
- **Bar spacing:** 12 mm as standard. 6 mm as option.
- **Grille width:** 50 mm to 300 mm with increments of 50 mm.
- **Length:** 1 meter as standard. Available from 0.2 mt to 5.8 mt in a single piece.
- **Damper frame and blades:** High quality extruded aluminium profiles with natural aluminium finish. Black matt finish as option.

## Description:

- Frame and face bars are of high quality extruded aluminium profiled construction with the advantages of corrosion resistance and rigidity.
- Horizontal face bars with 0°, 15° – 1 way throw and 15° – 2 way throw are fixed rigidly to the frame with 8-mm pipes.
- Vertical aluminium aerofoil blades are fixed at the rear side of the frame by nylon bushes. These blades can be adjusted manually and individually in the vertical plane to obtain optimum air distribution.



- Grilles are fixed rigidly with an opposed blade damper by grippers to ensure positive control over the air stream. Damper blades can be screw operated from the face opening of the grille.
- Provided with alignment strip for continuous appearance. Foam gasket is sealed around the back of the frame to avoid air leakage.
- Supplied with C- Clamps for concealed fixing.

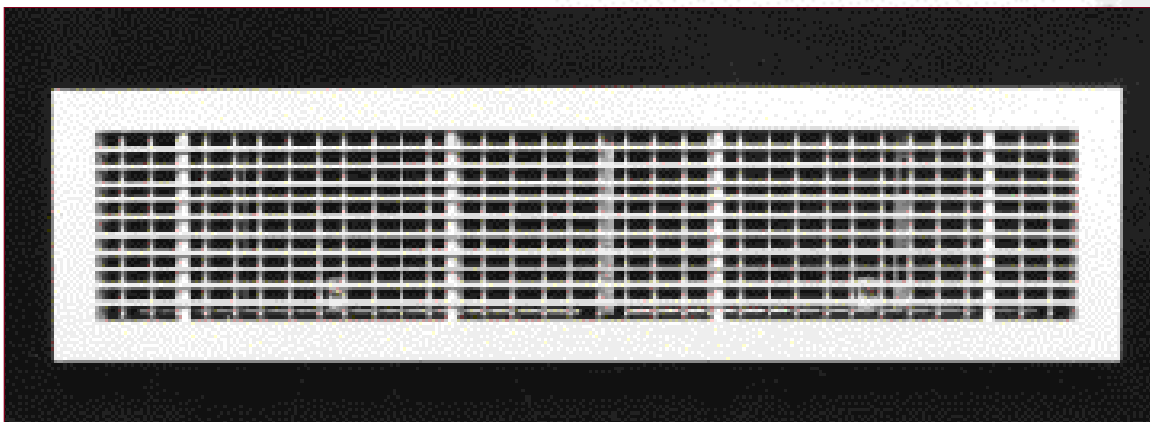
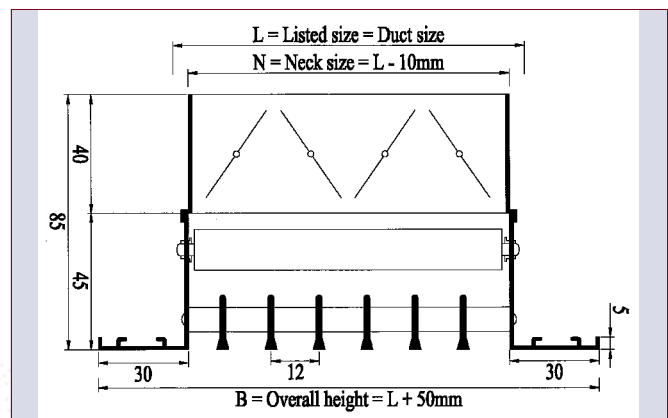



air master

# Return air linear bar grille

► Model: ARLG

## Construction:

- **Frame:** High quality extruded aluminium profile with 30 mm flange width as standard. 12, 16, 24 mm flange widths are optional.
- **Face bars:** High quality aluminium profiles of 0°, 15° – 1 way throw and 15° – 2 way throw.
- **Bar spacing:** 12 mm as standard. 6 mm as option.
- **Grille width:** 50 mm to 300 mm with increments of 50 mm.
- **Length:** 1 meter as standard. Available from 0.2 mt to 5.8 mt in a single piece.

## Description:

- Frame and face bars are of high quality extruded aluminium profiled construction with the advantages of corrosion resistance and rigidity.
- Horizontal face bars with 0°, 15° – 1 way throw and 15° – 2 way throw are fixed rigidly to the frame with 8-mm pipes.
- For perfect unbroken appearance of continuous runs, alignment strips are provided with no additional cost.
- Total structure is manufactured by mechanical assembly, assuring rigidity and to maintain straight-line appearance.



- Foam gasket is sealed around the back of the frame as option to avoid air leakage.
- Supplied with C - clamps for concealed fixing.

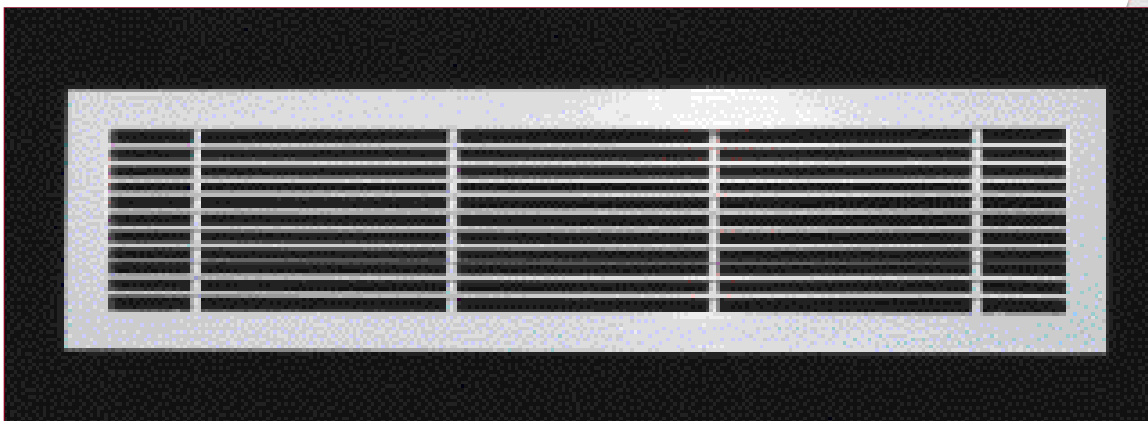
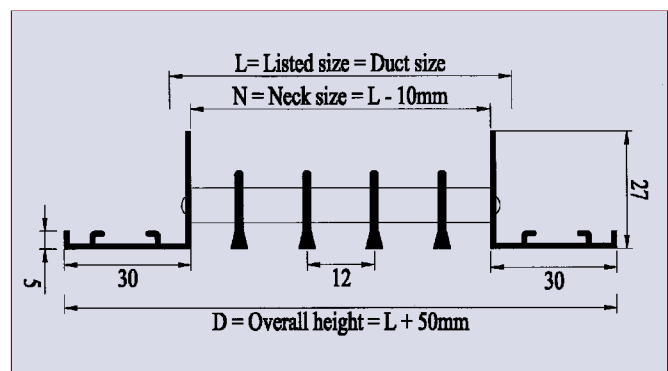



air master

# Return air linear bar Register

Model: ARLR

## Construction:

- **Frame:** High quality extruded aluminium profile with 30 mm flange width as standard. 12, 16, 24 mm flange widths are optional.
- **Face bars:** High quality aluminium profiles of 0°, 15° – 1 way throw and 15° – 2 way throw.
- **Bar spacing:** 12 mm as standard. 6 mm as option.
- **Grille width:** 50 mm to 300 mm with increments of 50 mm.
- **Length:** 1 meter as standard. Available from 0.2 mt to 5.8 mt in a single piece.
- **Damper frame and blades:** High quality extruded aluminium profiles with natural aluminium finish. Black matt finish as option.

## Description:

- Frame and face bars are of high quality extruded aluminium profiled construction with the advantages of corrosion resistance and rigidity.
- Horizontal face bars with 0°, 15° – 1 way throw and 15° – 2 way throw are fixed rigidly to the frame with 8-mm pipes.
- Grilles are fixed rigidly with opposed blade damper by grippers. This ensures positive control over the air stream. Damper blades can be screw operated from the face opening.



- For perfect unbroken appearance of continuous runs, alignment strips are provided with no additional cost.
- Foam gasket is sealed around the back of the frame as option to avoid air leakage.
- Supplied with C clamps for concealed fixing.

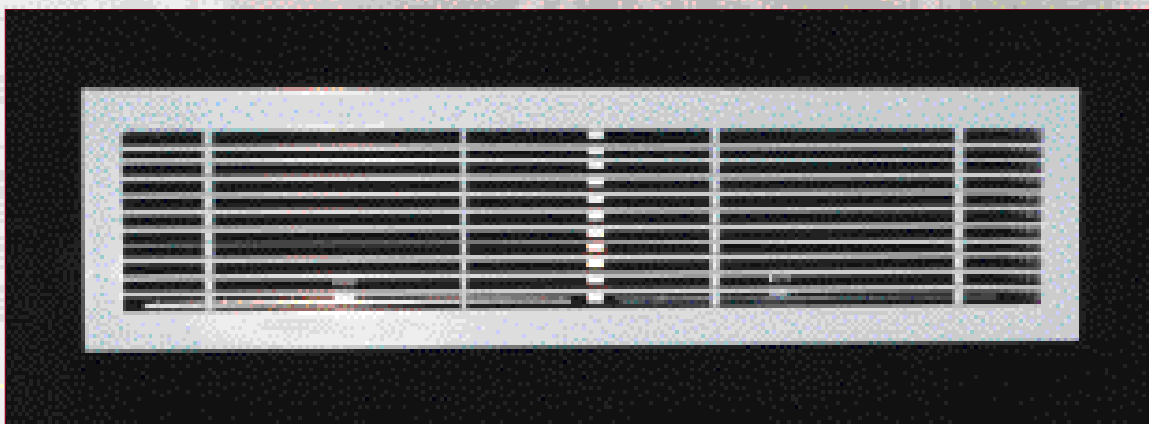
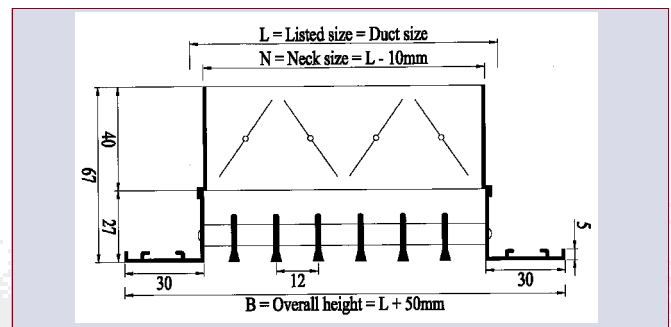



air master

# Supply air curved linear bar grille

► Model: ASLG (C)

## Construction:

- **Frame:** High quality extruded aluminium profile with 30 mm flange width as standard. 12, 16, 24 mm flange widths are optional.
- **Face bars:** High quality aluminium profiles of 0° – 1 way throw and 15° – 2 way throw.
- **Bar spacing:** 12 mm as standard. 6 mm as option.
- **Grille width:** 50 mm to 300 mm with increments of 50 mm.
- **Length:** 1 meter as standard.

## Description:

- Frame and face bars are of high quality extruded aluminium profiled construction with the advantages of corrosion resistance and rigidity.
- Horizontal face bars with 0° – 1 way throw and 15° – 2 way throw are fixed rigidly to the frame with 8-mm pipes.
- Vertical aluminium aerofoil blades are fixed at the rear side of the frame by nylon bushings. These blades can be adjusted manually and individually in the vertical plane to obtain optimum air distribution.
- For perfect unbroken appearance of continuous runs, alignment strips are provided with no additional cost.



- Supply and return air curved linear bar grilles are available up to a length of 3 mts with a minimum radius of curvature of 1 meter.
- Available without damper. Dampers can be provided to use in plenum boxes as option.
- Foam gasket is sealed around the back of the frame as option to avoid air leakage.
- Supplied with C clamps for concealed fixing.

**Model: ARLG-C:** Same as ASLG-C, without vertical aerofoil blades.

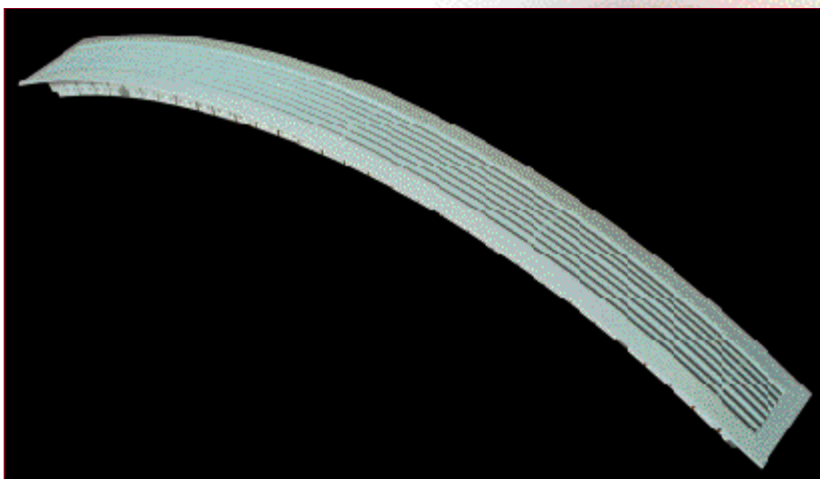
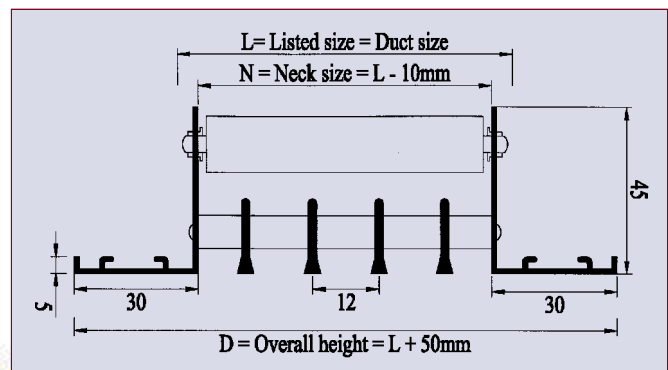



air master

# Supply air linear bar register with 6 mm pitch

► Model: ASLR (S)

## Construction:

- **Frame:** High quality extruded aluminium profile with 30 mm flange width as standard. 12, 16, 24 mm flange widths are optional.
- **Face bars:** High quality aluminium profiles of 0°, 15° – 1 way throw and 15° – 2 way throw.
- **Bar spacing:** 6 mm.
- **Grille width:** 50 mm to 300 mm with increments of 50 mm.
- **Length:** 1 meter as standard. Available from 0.2 mt to 5.8 mt in a single piece.
- **Damper frame and blades:** High quality extruded aluminium profiles with natural aluminium finish. Black matt finish as option.

## Description:

- Frame and face bars are of high quality extruded aluminium profiled construction with the advantages of corrosion resistance and rigidity.
- Horizontal face bars with 0°, 15° – 1 way throw and 15° – 2 way throw are fixed rigidly to the frame with 8-mm pipes.
- Vertical aluminium aerofoil blades are fixed at the rear side of the frame by nylon bushings. These blades can be adjusted manually and individually in the vertical plane to obtain optimum air distribution.



- Grilles are fixed rigidly with an opposed blade damper by grippers to ensure positive control over the air stream. Damper blades can be screw operated from the face opening of the grille.
- For perfect unbroken appearance of continuous runs, alignment strips are provided with no additional cost. Foam gasket is sealed around the back of the frame as option to avoid air leakage.
- Supplied with C clamps for concealed fixing.
- Also available without damper and vertical blades for return air applications.

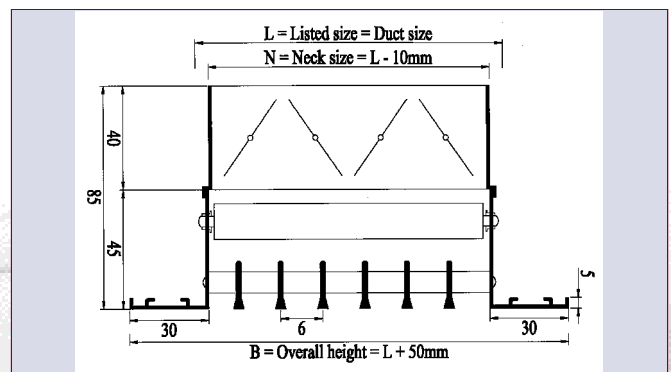



air master

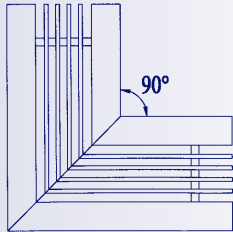
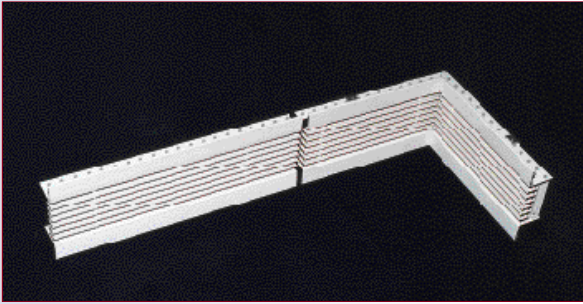

3a) 90° Horizontal

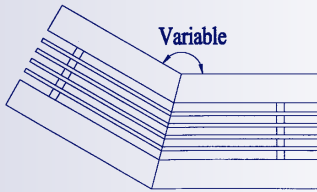

3b) Variable angle (90° - 180°)

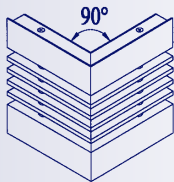

3c) 90° Vertical outside

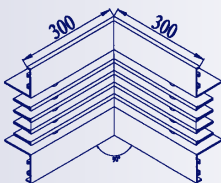

3d) 90° Vertical inside

**Standard finishes:**

- Natural anodized aluminum finish.
- Powder coated colour finish as per RAL colour codes.
- Flexibility of finishing is available as option.

**Optional mitered corners**

Standard 90° horizontal mitered corner available for floor, sill and ceiling applications in 0°, 15° one way throw and 15° two way throw without damper.

Special horizontal mitered corner selection available for floor, sill and ceiling applications includes an angle greater than 90° and less than 180° available in 0°, 15° one way throw and 15° two way throw without damper.

Vertical outside mitered corners are available for wall application at the junction of two outside walls with a standard angle of 90°. Available in 0°, 15° one way throw and 15° two way throw without damper.

Vertical inside mitered corners are available for wall application at the junction of two inside walls with a standard angle of 90°. Available in 0°, 15° one way throw and 15° two way throw without damper.



air master

# Bar deflections

Standard: ←

MODEL	0° one way	15° one way
ASLG		
ASLR		
ARLG		
ARLR		

## Optional

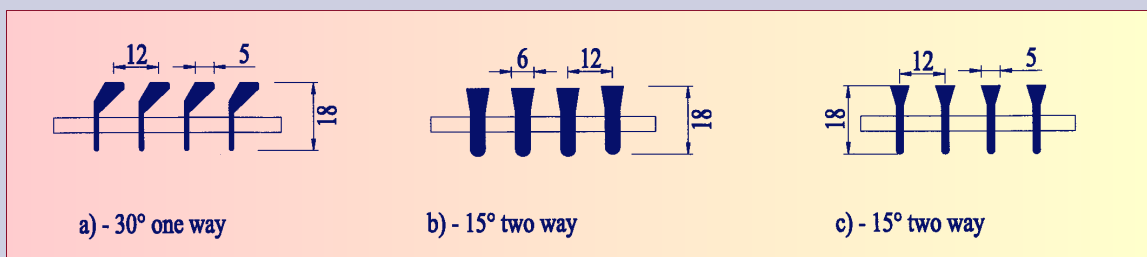



air master

## Accessories:

### A. Linear bar grille with one side access door:

Access door will be provided either right or left side of the grille for special applications upon request. Size of the door is optional.

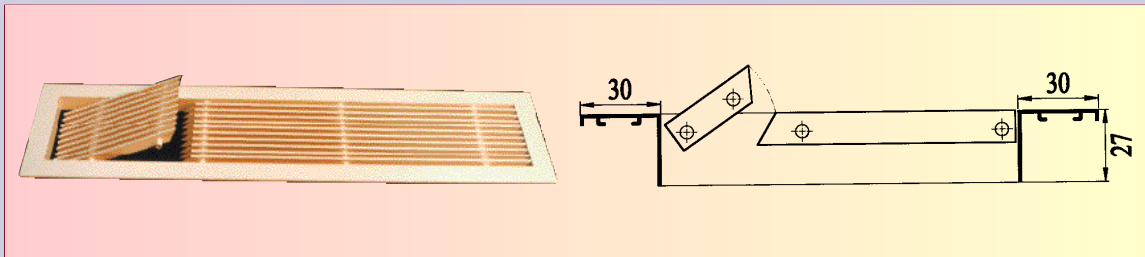

### B. Linear bar grille with both side access doors:

Access door will be provided to both sides of the grille for special applications upon request. Size of the door is optional.

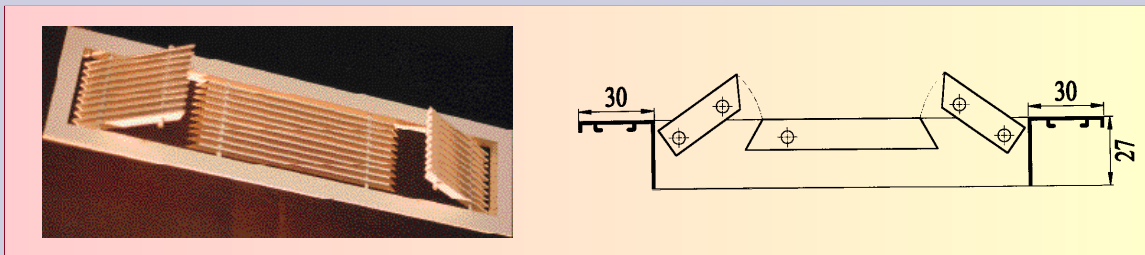

### End flanges:

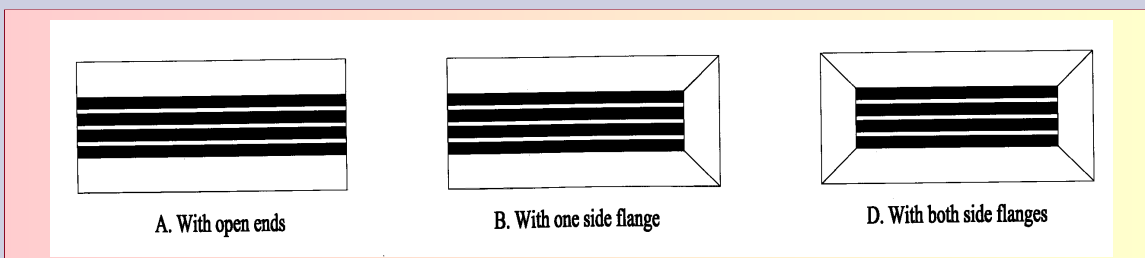



air master

## Fixing details

- **C - clamp fixing:**

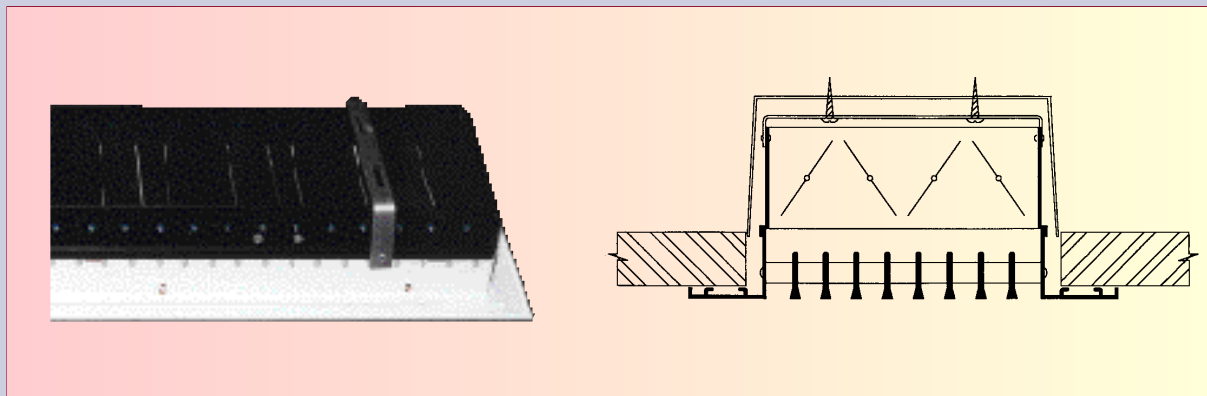

- **Fixing to the plenum box.**

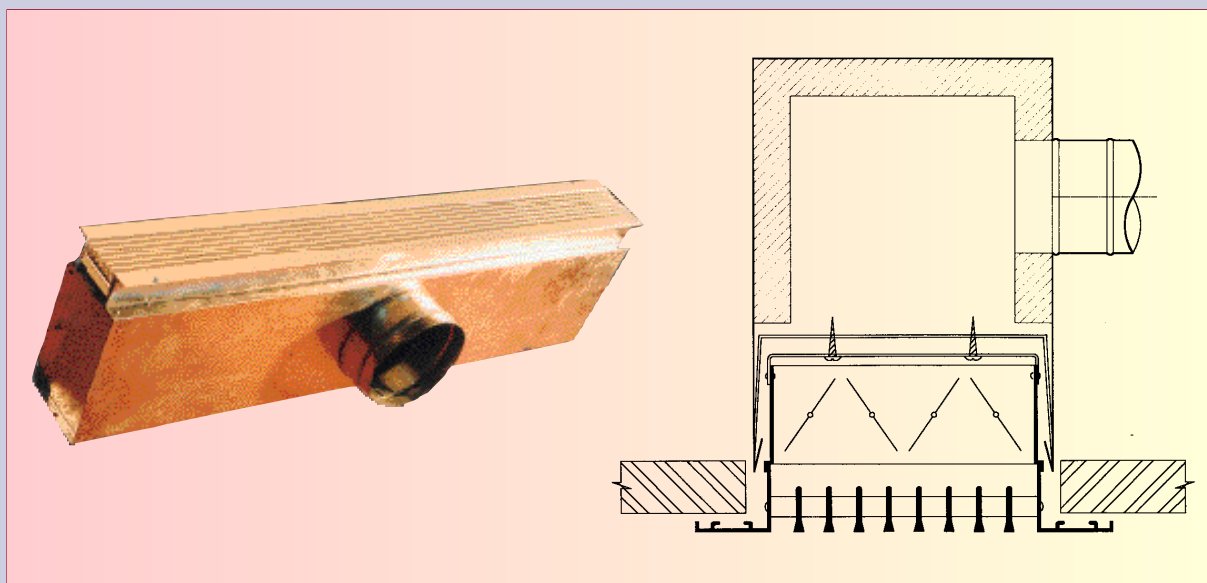



**air master**

**Standard Sizes:**

- Grilles are available with 1 meter length as standard.
- Length from 0.2 m to 5.8 mt is available as single piece.
- Non standard sizes available as option.

Listed Width in mm	50	100	150	200	250	300
--------------------	----	-----	-----	-----	-----	-----

**How to order:**

Model	Face bars	Size	End flange details	Quantity	Finish
ASLG	0 = 0°	Specify duct opening size Length x height in mm x mm	A. With open ends.	Specify in numbers.	A. Natural anodized aluminium finish.
ASLR	1 = 15° one way		B. One side end flange. Right (or) Left.		B. RAL 9010
ARLG	2 = 15° two way		C. Both sides Flanges.		C. Other RAL colours.
ARLR					

Tick the required item.

**Ordering example:**

1. To select supply air linear bar register with 15° – 2 way face bars of size 1500 x 150 mm with open ends of Quantity = 70 numbers, with white powder coated colour finish (RAL 9010).

**Order as :** ASLR - 2-1500 x 150 - A – 70 - B.

2. To select supply air linear bar grille of 6 pitch, 15° – 1 way face bars of size 1000 x 150 mm with end flanges of Quantity = 50 numbers, with natural anodized aluminium finish.

**Order as :** ASLG (S)-1-1000 x 150 - C – 50 - A.





air master

# Supply linear bar register

15° -2 way - 12 mm spacing

► Model: ASLR

**Table 3.1 Air flow data**

Width in mm A <sub>k</sub> in m <sup>2</sup>	Face Velocity in m/sec.	2.0	2.5	3.0	3.5	4.0	4.5	5.0
50 0.039	Cfm M <sup>3</sup> /sec. P <sub>s</sub> in mm H <sub>2</sub> O Throw in m NC	165 0.078 0.15 2.7-4.0-5.5 <15	207 0.098 0.21 3.4-4.3-6.0 <15	248 0.117 0.21 4.0-4.9-6.7 <15	290 0.137 0.25 4.3-5.2-7.3 16	330 0.156 0.32 4.6-5.5-7.6 22	373 0.176 0.4 4.9-5.8-8.2 25	413 0.195 0.51 4.9-6.0-8.5 30
100 0.059	Cfm M <sup>3</sup> /sec. P <sub>s</sub> in mm H <sub>2</sub> O Throw in m NC	250 0.118 0.15 3.4-4.6-7.0 <15	313 0.148 0.21 4.0-5.2-7.6 <15	375 0.177 0.21 4.6-5.8-8 <15	438 0.207 0.3 5.2-6.0-8.5 17	500 0.236 0.39 5.5-6.7-9.1 22	563 0.266 0.51 5.8-7.3-10 27	625 0.295 0.61 6-7.6-10.7 31
150 0.078	Cfm M <sup>3</sup> /sec. P <sub>s</sub> in mm H <sub>2</sub> O Throw in m NC	330 0.156 0.15 4.0-5.5-8.0 <15	413 0.195 0.21 4.6-6.0-8.8 <15	495 0.234 0.25 5.2-6.7-9.5 <15	578 0.273 0.36 5.8-7.3-10 17	660 0.312 0.46 6.4-8-10.7 23	743 0.351 0.58 6.7-8.5-11.6 28	825 0.39 0.71 7-8.8-12.2 32
200 0.097	Cfm M <sup>3</sup> /sec. P <sub>s</sub> in mm H <sub>2</sub> O Throw in m NC	410 0.194 0.2 4.5-6.1-8.8 <15	515 0.243 0.23 5.2-6.7-9.8 <15	616 0.291 0.31 6.0-7.6-10.7 16	718 0.339 0.39 6.7-8.0-11.3 21	821 0.388 0.53 7.3-8.8-11.9 26	925 0.437 0.66 7.6-9.5-12.8 31	1027 0.485 0.91 8.0-9.8-13.7 35
250 0.116	Cfm M <sup>3</sup> /sec. P <sub>s</sub> in mm H <sub>2</sub> O Throw in m NC	491 0.232 0.2 4.9-6.7-9.8 <15	614 0.29 0.25 5.5-7.6-10.7 <15	736 0.348 0.33 6.4-8.2-11.3 20	860 0.406 0.43 7.3-8.8-12.2 25	982 0.464 0.58 8.0-9.5-13.1 31	1105 0.522 0.76 8.2-10-14 34	1228 0.58 0.94 8.5-10.7-15 37
300 0.136	Cfm M <sup>3</sup> /sec. P <sub>s</sub> in mm H <sub>2</sub> O Throw in m NC	576 0.272 0.2 5.2-7.3-10.7 <15	720 0.34 0.31 6.1-8.2-11.6 18	864 0.408 0.36 7-9.1-12.2 24	1008 0.476 0.47 7.9-9.8-13.1 28	1152 0.544 0.64 8.5-10.4-14 32	1295 0.612 0.85 8.8-11-15 35	1440 0.68 1.02 9.1-11.6-16.2 40

- Data based on one meter unit length of the grille with damper in full open position.
- Face velocity is measured in m/sec.
- P<sub>s</sub>: Static pressure loss is in mm of H<sub>2</sub>O.
- Throw (meters) is measured for a terminal velocities of 0.75, 0.5 & 0.25 m/sec.
- NC based on a room attenuation of 10 dB.



air master

# Supply linear bar register

15° -1 way - 12 mm spacing

► Model: ASLR-1

**Table 3.2 Air flow data**

Width in mm A <sub>k</sub> in m <sup>2</sup>	Face Velocity in m/sec.	2.0	2.5	3.0	3.5	4.0	4.5	5.0
50 0.040	Cfm	169	212	254	296	339	381	423
	M <sup>3</sup> /sec.	0.08	0.1	0.12	0.14	0.16	0.18	0.2
	P <sub>s</sub> in mm H <sub>2</sub> O	0.14	0.19	0.21	0.25	0.31	0.39	0.5
	Throw in m	2.7-4.1-5.6	3.5-4.4-6.2	4.1-5.0-7.0	4.5-5.4-7.7	4.8-5.8-8.1	5.1-6.1-8.9	5.2-6.4-9.3
	NC	<15	<15	<15	17	22	25	31
100 0.065	Cfm	275	345	413	483	550	620	688
	M <sup>3</sup> /sec.	0.13	0.163	0.195	0.228	0.26	0.293	0.325
	P <sub>s</sub> in mm H <sub>2</sub> O	0.14	0.19	0.21	0.3	0.38	0.5	0.6
	Throw in m	3.5-4.7-7.1	4.1-5.3-7.8	4.7-5.9-8.4	5.4-6.2-9.0	5.8-7.0-9.7	6.1-7.7-10.8	6.4-8.1-11.7
	NC	<15	<15	15	18	23	27	32
150 0.088	Cfm	373	466	559	652	745	838	932
	M <sup>3</sup> /sec.	0.176	0.22	0.264	0.308	0.352	0.396	0.44
	P <sub>s</sub> in mm H <sub>2</sub> O	0.14	0.19	0.25	0.36	0.45	0.57	0.7
	Throw in m	4.1-5.6-8.2	4.7-6.2-9.0	5.4-6.9-10	6.0-7.6-10.6	6.7-8.4-11.4	7.0-8.9-12.5	7.4-9.3-13.3
	NC	<15	<15	16	18	24	29	34
200 0.111	Cfm	470	589	705	824	940	1058	1175
	M <sup>3</sup> /sec.	0.222	0.278	0.333	0.389	0.444	0.499	0.555
	P <sub>s</sub> in mm H <sub>2</sub> O	0.18	0.21	0.31	0.39	0.52	0.65	0.9
	Throw in m	4.6-6.2-9.0	5.3-6.9-10.0	6.2-7.8-11.2	6.9-8.3-11.9	7.7-9.2-12.7	8-9.9-13.8	8.5-10.4-14.9
	NC	<15	16	17	21	26	32	36
250 0.134	Cfm	567	709	851	993	1135	1277	1419
	M <sup>3</sup> /sec.	0.268	0.335	0.402	0.469	0.536	0.603	0.67
	P <sub>s</sub> in mm H <sub>2</sub> O	0.2	0.25	0.33	0.42	0.56	0.77	0.93
	Throw in m	5.0-6.8-10	5.6-7.8-11	6.6-8.4-11.9	7.6-9.2-12.9	8.4-10-14	8.6-10.5-15.1	9.0-11.3-16.4
	NC	<15	16	21	27	31	35	40
300 0.162	Cfm	686	857	1029	1200	1372	1543	1715
	M <sup>3</sup> /sec.	0.324	0.405	0.486	0.567	0.648	0.729	0.81
	P <sub>s</sub> in mm H <sub>2</sub> O	0.2	0.3	0.36	0.47	0.64	0.84	1.01
	Throw in m	5.3-7.5-10.9	6.2-8.4-11.9	7.2-9.4-12.8	8.2-10.2-13.9	8.9-10.9-15	9.2-11.6-16.2	9.6-12.3-17.6
	NC	<15	18	25	30	33	37	42

- Data based on one meter unit length of the grille with damper in full open position.
- Face velocity is measured in m/sec.
- P<sub>s</sub>: Static pressure loss is in mm of H<sub>2</sub>O.
- Throw (meters) is measured for a terminal velocities of 0.75, 0.5 & 0.25 m/sec.
- NC based on a room attenuation of 10 dB.



**air master**

# Supply linear bar register

0° -12 mm spacing

► Model: ASLR-0

**Table 3.3 Air flow data**

Width in mm A <sub>k</sub> in m <sup>2</sup>	Face Velocity in m/sec.	2.0	2.5	3.0	3.5	4.0	4.5	5.0
50 0.040	Cfm M <sup>3</sup> /sec. P <sub>s</sub> in mm H <sub>2</sub> O Throw in m NC	169 0.08 0.14 2.7-4.1-5.6 <15	212 0.1 0.19 3.5-4.4-6.2 <15	254 0.12 0.19 4.2-5.1-7.1 <15	296 0.14 0.23 4.6-5.6-7.9 17	339 0.16 0.28 4.9-5.6-8.3 22	381 0.18 0.36 5.4-6.4-9.3 25	423 0.2 0.46 5.5-6.8-9.8 31
100 0.065	Cfm M <sup>3</sup> /sec. P <sub>s</sub> in mm H <sub>2</sub> O Throw in m NC	275 0.13 0.14 3.5-4.7-7.1 <15	345 0.163 0.19 4.1-5.3-7.8 <15	413 0.195 0.19 4.8-6.0-8.6 15	483 0.228 0.28 5.6-6.4-9.3 18	550 0.26 0.35 5.9-7.2-10.0 23	620 0.293 0.46 6.4-8.1-11.3 27	688 0.325 0.56 6.8-8.6-12.4 32
150 0.088	Cfm M <sup>3</sup> /sec. P <sub>s</sub> in mm H <sub>2</sub> O Throw in m NC	373 0.176 0.14 4.1-5.6-8.2 <15	466 0.22 0.19 4.7-6.2-9.0 <15	559 0.264 0.23 5.5-7-10.2 16	652 0.308 0.33 6.2-7.8-10.9 18	745 0.352 0.42 6.9-8.7-11.7 24	838 0.396 0.53 7.4-9.3-13.1 29	932 0.44 0.65 7.8-9.8-14.0 34
200 0.111	Cfm M <sup>3</sup> /sec. P <sub>s</sub> in mm H <sub>2</sub> O Throw in m NC	470 0.222 0.16 4.6-6.2-9.0 <15	589 0.278 0.19 5.3-6.9-10.0 16	705 0.333 0.28 6.3-7.9-11.4 17	824 0.389 0.36 7.1-8.5-12.3 21	940 0.444 0.48 7.9-9.5-13.1 26	1058 0.499 0.6 8.4-10.4-14.5 32	1175 0.555 0.84 9.0-11.0-15.8 36
250 0.134	Cfm M <sup>3</sup> /sec. P <sub>s</sub> in mm H <sub>2</sub> O Throw in m NC	567 0.268 0.19 5.0-6.8-10 <15	709 0.335 0.23 5.6-7.8-11 16	851 0.402 0.31 6.7-8.6-12.1 21	993 0.469 0.39 7.8-9.5-13.3 27	1135 0.536 0.52 8.6-10.3-14.4 31	1277 0.603 0.71 9.0-11-15.9 35	1419 0.67 0.86 9.5-11.9-17.4 40
300 0.162	Cfm M <sup>3</sup> /sec. P <sub>s</sub> in mm H <sub>2</sub> O Throw in m NC	686 0.324 0.19 5.3-7.5-10.9 <15	857 0.405 0.28 6.2-8.4-11.9 18	1029 0.486 0.33 7.3-9.6-13.0 25	1200 0.567 0.44 8.4-10.5-14.3 30	1372 0.648 0.59 9.2-11.2-15.4 33	1543 0.729 0.78 9.6-12.2-17.0 37	1715 0.81 0.94 10.2-13-18.6 42

- Data based on one meter unit length of the grille with damper in full open position.
- Face velocity is measured in m/sec.
- P<sub>s</sub>: Static pressure loss is in mm of H<sub>2</sub>O.
- Throw (meters) is measured for a terminal velocities of 0.75, 0.5 & 0.25 m/sec.
- NC based on a room attenuation of 10 dB.



air master

# Return linear bar register

15° -2 way - 12 mm spacing

► Model: ARLR

**Table 3.4 Air flow data**

Nominal Width mm							
50	Cfm	332	417	500	585	667	750
	M <sup>3</sup> /sec.	0.157	0.197	0.236	0.276	0.315	0.354
	-P <sub>s</sub> in mm H <sub>2</sub> O	0.48	0.74	1.07	1.47	1.91	2.41
	NC	<15	18	26	32	36	42
100	Cfm	417	500	585	667	750	833
	M <sup>3</sup> /sec.	0.197	0.236	0.276	0.315	0.354	0.393
	-P <sub>s</sub> in mm H <sub>2</sub> O	0.51	0.71	0.97	1.27	1.6	1.98
	NC	15	20	27	32	35	40
150	Cfm	500	585	667	750	833	1000
	M <sup>3</sup> /sec.	0.236	0.276	0.315	0.354	0.393	0.472
	-P <sub>s</sub> in mm H <sub>2</sub> O	0.51	0.69	0.89	1.14	1.40	2.01
	NC	17	22	28	32	34	38
200	Cfm	585	667	750	833	1000	1167
	M <sup>3</sup> /sec.	0.276	0.315	0.354	0.393	0.472	0.551
	-P <sub>s</sub> in mm H <sub>2</sub> O	0.48	0.64	0.81	0.99	1.42	1.91
	NC	16	23	26	32	35	40
250	Cfm	667	750	833	1000	1167	1332
	M <sup>3</sup> /sec.	0.315	0.354	0.393	0.472	0.551	0.629
	-P <sub>s</sub> in mm H <sub>2</sub> O	0.48	0.61	0.74	1.07	1.45	1.9
	NC	19	23	25	31	35	40
300	Cfm	750	833	1000	1167	1333	1500
	M <sup>3</sup> /sec.	0.354	0.393	0.472	0.551	0.629	0.708
	-P <sub>s</sub> in mm H <sub>2</sub> O	0.5	0.64	0.77	1.13	1.52	2.0
	NC	20	25	27	31	38	44

- Data based on one meter unit length of the grille.
- P<sub>s</sub>: Static pressure loss is in mm of H<sub>2</sub>O.
- NC based on a room attenuation of 10 dB.



air master

# Return linear bar register

15° -1 way - 12 mm spacing

► Model: ARLR-1

**Table 3.5 Air flow data**

Nominal Width mm							
50	Cfm	332	417	500	585	667	750
	M <sup>3</sup> /sec.	0.157	0.197	0.236	0.276	0.315	0.354
	-P <sub>s</sub> in mm H <sub>2</sub> O	0.46	0.72	1.03	1.42	1.88	2.32
	NC	<15	<18	25	31	31	40
100	Cfm	417	500	585	667	750	833
	M <sup>3</sup> /sec.	0.197	0.236	0.276	0.315	0.354	0.393
	-P <sub>s</sub> in mm H <sub>2</sub> O	0.48	0.69	0.93	1.20	1.55	1.88
	NC	<15	19	24	31	34	38
150	Cfm	500	585	667	750	833	1000
	M <sup>3</sup> /sec.	0.236	0.276	0.315	0.354	0.393	0.472
	-P <sub>s</sub> in mm H <sub>2</sub> O	0.48	0.67	0.86	1.10	1.34	1.92
	NC	15	20	27	31	31	37
200	Cfm	585	667	750	833	1000	1167
	M <sup>3</sup> /sec.	0.276	0.315	0.354	0.393	0.472	0.551
	-P <sub>s</sub> in mm H <sub>2</sub> O	0.45	0.64	0.78	0.99	1.37	1.85
	NC	17	23	25	30	34	38
250	Cfm	667	750	833	1000	1167	1332
	M <sup>3</sup> /sec.	0.315	0.354	0.393	0.472	0.551	0.629
	-P <sub>s</sub> in mm H <sub>2</sub> O	0.45	0.59	0.71	1.02	1.36	1.79
	NC	19	22	24	30	33	38
300	Cfm	750	833	1000	1167	1332	1500
	M <sup>3</sup> /sec.	0.354	0.393	0.472	0.551	0.629	0.708
	-P <sub>s</sub> in mm H <sub>2</sub> O	0.48	0.6	0.74	1.05	1.45	1.8
	NC	19	23	25	30	37	42

- Data based on one meter unit length of the grille.
- P<sub>s</sub>: Static pressure loss is in mm of H<sub>2</sub>O.
- NC based on a room attenuation of 10 dB.



air master

# Return linear bar register

0° -12 mm spacing

► Model: ARLR-0

**Table 3.6 Air flow data**

Nominal Width mm							
50	Cfm	332	417	500	585	667	750
	M <sup>3</sup> /sec.	0.157	0.197	0.236	0.276	0.315	0.354
	-P <sub>s</sub> in mm H <sub>2</sub> O	0.43	0.69	0.99	1.37	1.83	2.23
	NC	<15	17	24	30	33	38
100	Cfm	417	500	585	667	750	833
	M <sup>3</sup> /sec.	0.197	0.236	0.276	0.315	0.354	0.393
	-P <sub>s</sub> in mm H <sub>2</sub> O	0.45	0.66	0.89	1.14	1.48	1.78
	NC	<15	18	23	31	33	36
150	Cfm	500	585	667	750	833	1000
	M <sup>3</sup> /sec.	0.236	0.276	0.315	0.354	0.393	0.472
	-P <sub>s</sub> in mm H <sub>2</sub> O	0.45	0.64	0.81	1.04	1.27	1.83
	NC	15	17	26	28	30	36
200	Cfm	585	667	750	833	1000	1167
	M <sup>3</sup> /sec.	0.276	0.315	0.354	0.393	0.472	0.551
	-P <sub>s</sub> in mm H <sub>2</sub> O	0.43	0.64	0.65	0.91	1.4	1.8
	NC	17	22	24	27	33	37
250	Cfm	667	750	833	1000	1167	1332
	M <sup>3</sup> /sec.	0.315	0.354	0.393	0.472	0.551	0.629
	-P <sub>s</sub> in mm H <sub>2</sub> O	0.43	0.56	0.66	0.94	1.27	1.67
	NC	19	21	23	29	32	36
300	Cfm	750	833	1000	1167	1330	1500
	M <sup>3</sup> /sec.	0.354	0.393	0.472	0.551	0.629	0.708
	-P <sub>s</sub> in mm H <sub>2</sub> O	0.45	0.58	0.69	0.98	1.32	1.7
	NC	19	22	24	28	36	40

- Data based on one meter unit length of the grille.
- P<sub>s</sub>: Static pressure loss is in mm of H<sub>2</sub>O.
- NC based on a room attenuation of 10 dB.



air master

# Supply linear bar register

15° -2 way - 6 mm spacing

► Model: ASLR (S)

**Table 3.7 Air flow data**

Width in mm A <sub>k</sub> in m <sup>2</sup>	Face Velocity in m/sec.	2.0	2.5	3.0	3.5	4.0	4.5	5.0
50	Cfm M <sup>3</sup> /sec. P <sub>s</sub> in mm H <sub>2</sub> O Throw in m NC	85 0.04 0.16 2.8-4.2-5.8 <15	106 0.05 0.23 3.6-4.5-6.3 <15	127 0.06 0.23 4.3-5.3-7.2 <15	148 0.07 0.28 4.6-5.6-7.9 18	169 0.08 0.36 5.1-6.0-8.4 24	190 0.09 0.45 5.4-6.4-9.0 28	212 0.1 0.59 5.4-6.6-9.4 33
100	Cfm M <sup>3</sup> /sec. P <sub>s</sub> in mm H <sub>2</sub> O Throw in m NC	148 0.07 0.16 3.6-4.8-7.3 <15	186 0.088 0.23 4.2-5.5-7.9 <15	222 0.105 0.23 4.9-6.3-8.6 17	260 0.123 0.33 5.6-6.5-9.2 20	296 0.14 0.44 6.0-7.4-10.0 25	335 0.158 0.58 6.4-8.11 29	370 0.175 0.7 6.7-8.4-11.9 34
150	Cfm M <sup>3</sup> /sec. P <sub>s</sub> in mm H <sub>2</sub> O Throw in m NC	224 0.106 0.16 4.2-5.8-8.4 <15	282 0.133 0.23 4.8-6.3-9.2 <15	337 0.159 0.28 5.6-7.2-10.3 17	394 0.186 0.4 6.3-7.9-10.8 20	449 0.212 0.52 7.0-8.8-11.8 27	504 0.238 0.66 7.4-9.4-12.8 30	561 0.261 0.82 7.8-9.8-13.5 35
200	Cfm M <sup>3</sup> /sec. P <sub>s</sub> in mm H <sub>2</sub> O Throw in m NC	284 0.134 0.22 4.7-6.4-9.2 <15	356 0.168 0.25 5.5-7-10.3 <15	426 0.201 0.34 6.5-8.2-11.6 18	498 0.235 0.43 7.2-8.6-12.2 23	567 0.268 0.6 8-9.7-13.0 29	639 0.302 0.75 8.4-10.4-14 34	709 0.335 1.05 8.9-10.9-15.2 39
250	Cfm M <sup>3</sup> /sec. P <sub>s</sub> in mm H <sub>2</sub> O Throw in m NC	360 0.17 0.22 5.1-7-10.3 15	451 0.213 0.27 5.7-7.9-11.2 17	540 0.255 0.37 6.9-8.8-12.2 23	631 0.298 0.48 7.9-9.5-13.2 28	720 0.34 0.66 8.8-10.4-14.4 35	811 0.383 0.86 9.0-11-15.4 39	900 0.425 1.08 9.4-11.9-16.6 42
300	Cfm M <sup>3</sup> /sec. P <sub>s</sub> in mm H <sub>2</sub> O Throw in m NC	436 0.206 0.22 5.4-7.7-11.2 15	546 0.258 0.34 6.4-8.6-12.2 19	654 0.309 0.40 7.6-9.8-13.2 27	764 0.361 0.52 8.5-10.6-14 31	872 0.412 0.72 9.4-11.4-15.4 37	982 0.464 0.96 9.7-12.1-16.5 40	1090 0.515 1.17 10-12.9-18 45

- Data based on one meter unit length of the grille with damper in full open position.
- Face velocity is measured in m/sec.
- P<sub>s</sub>: Static pressure loss is in mm of H<sub>2</sub>O.
- Throw (meters) is measured for a terminal velocities of 0.75, 0.5 & 0.25 m/sec.
- NC based on a room attenuation of 10 dB.



air master

# Return linear bar register

15° -2 way - 6 mm spacing

Model: ARLR (S)

### Table 3.8 Air flow data

Nominal Width mm							
50	Cfm	170	213	255	298	340	382
	M <sup>3</sup> /sec.	0.08	0.101	0.12	0.141	0.161	0.18
	-P <sub>s</sub> in mm H <sub>2</sub> O	0.5	0.78	1.12	1.57	2.04	2.3
	NC	17	20	29	35	39	45
100	Cfm	247	296	347	395	445	494
	M <sup>3</sup> /sec.	0.117	0.139	0.164	0.187	0.21	0.233
	-P <sub>s</sub> in mm H <sub>2</sub> O	0.54	0.75	1.02	1.36	1.7	2.13
	NC	17	22	30	35	38	44
150	Cfm	340	398	454	510	566	680
	M <sup>3</sup> /sec.	0.161	0.188	0.214	0.241	0.267	0.321
	-P <sub>s</sub> in mm H <sub>2</sub> O	0.54	0.72	0.93	1.22	1.5	2.17
	NC	19	24	31	35	37	42
200	Cfm	404	461	518	576	691	806
	M <sup>3</sup> /sec.	0.191	0.218	0.245	0.272	0.326	0.381
	-P <sub>s</sub> in mm H <sub>2</sub> O	0.51	0.67	0.85	1.06	1.52	2.06
	NC	18	25	29	35	38	44
250	Cfm	487	548	608	730	852	972
	M <sup>3</sup> /sec.	0.23	0.259	0.287	0.345	0.402	0.459
	-P <sub>s</sub> in mm H <sub>2</sub> O	0.51	0.64	0.78	1.15	1.55	2.05
	NC	21	25	28	34	39	44
300	Cfm	570	633	760	887	1013	1140
	M <sup>3</sup> /sec.	0.269	0.299	0.359	0.419	0.478	0.538
	-P <sub>s</sub> in mm H <sub>2</sub> O	0.53	0.67	0.81	1.21	1.63	2.16
	NC	22	27	30	34	42	47

- Data based on one meter unit length of the grille.
- P<sub>s</sub>: Static pressure loss is in mm of H<sub>2</sub>O.
- NC based on a room attenuation of 10 dB.



# Double security bar register

- with steel housing

► Model: AMSR-D

## Construction:

- **Frame:** Heavy gauge high quality extruded aluminium profile with 30mm flange width as standard.
- **Face bars:** Heavy gauge extruded aluminium profiles of 0°, 15° - 1 way throw and 15° - 2 way throw. Steel bars are available as option.
- **Bar spacing:** 12 mm.
- **Damper frame and blades:** High quality extruded aluminium profiles with natural aluminium finish. Black matt finish as option.

## Description:

- Frame and face bars are of high quality extruded aluminium profiled construction with the advantages of corrosion resistance and rigidity.
- Horizontal face bars with 0°, 15° - 1 way throw and 15° - 2 way throw are fixed rigidly to the frame with steel rods welded to the main frame.
- Optional vertical aluminium aerofoil blades are fixed at the rear side of the frame by nylon bushings.
- Opposed blade damper is fixed to the main frame.
- Wall sleeves are made of heavy gauge galvanized steel.
- Security grilles are used in areas such as prisons, hospitals and production plants where security is of main concern

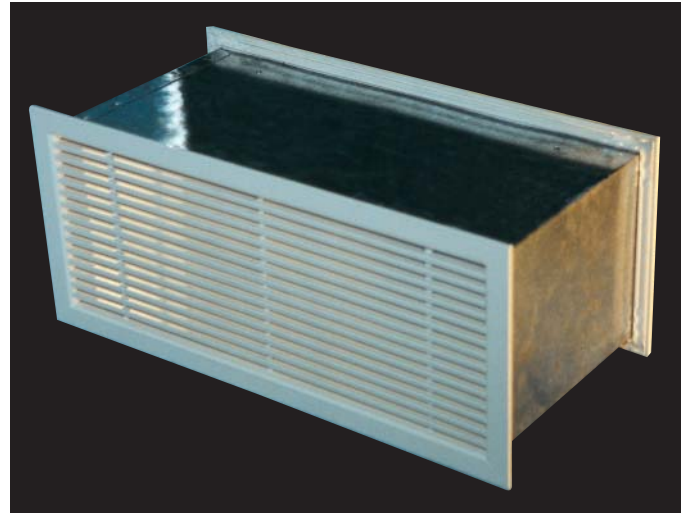

## Finishes:

- Anodised finish.
- Powder coated as per RAL color codes.

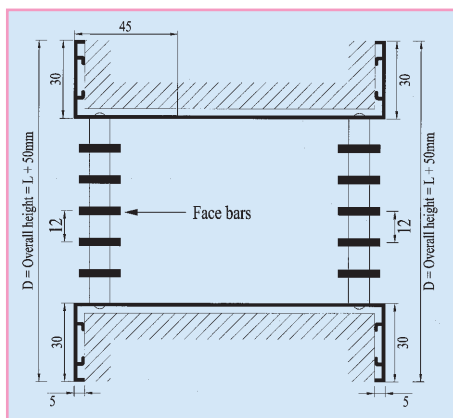

### Model: AMSG-D

Double security bar grille with steel housing.

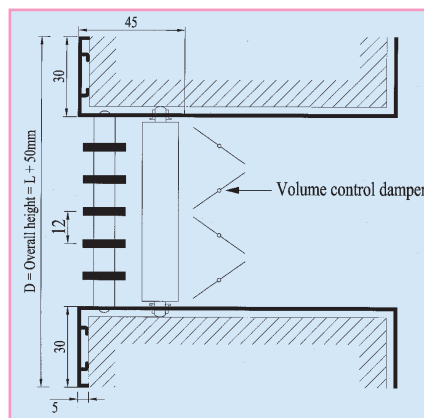

### Model: AMSR-S

Single security bar grille with volume control damper and steel housing.

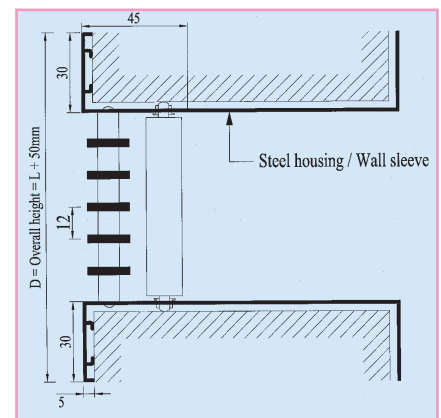

### Model: AMSG-S

Single security bar grille with steel housing.

## Fixing:

- Rivet fixing to the wall sleeve.
- Special tamper proof screw fixing.



## Maximum Security Perforated Grille

Model: AMPSG

### Construction:

- **Frame:** Resistant steel sheet of 4.5mm thick with welded corners.
- **Perforated Panel:** 4.5mm thick galvanised perforated steel sheet with 8mm holes.
- **Sleeves:** Wall sleeves are made of galvanised steel.

### Optional features:

- **Damper Frame:** Galvanised steel sheet.
- **Damper Core:** High quality extruded aluminium profile with natural aluminium finish and black matt finish.

### Description:

- Frame is constructed from 4.5mm thick resistant steel and all sides welded with 4.5mm thick perforated panel having 8mm dia holes. Whole structure is hot dip galvanised with the advantages of corrosion resistance.
- Security grilles are specially designed for maximum security prisons in order to secure the ventilation openings and provide proper air transfer for the facilities.
- The design prevents the inmates from using the grille to commit suicide
- Available with flanged edges and are supplied without fixing holes as standard.
- Available in square and rectangular sizes.

### Standard finishes:

- Hot dip galvanised.
- Powder coated as per RAL color codes.

### Fixing:

- 40mmx40mmx4mm Angle frame loose supplied, to be field welded on sleeve.
- Rivet fixing to the wall sleeve.
- Special tamper proof screw fixing.

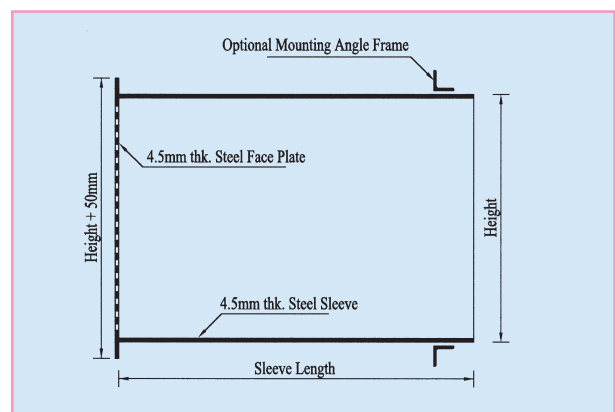
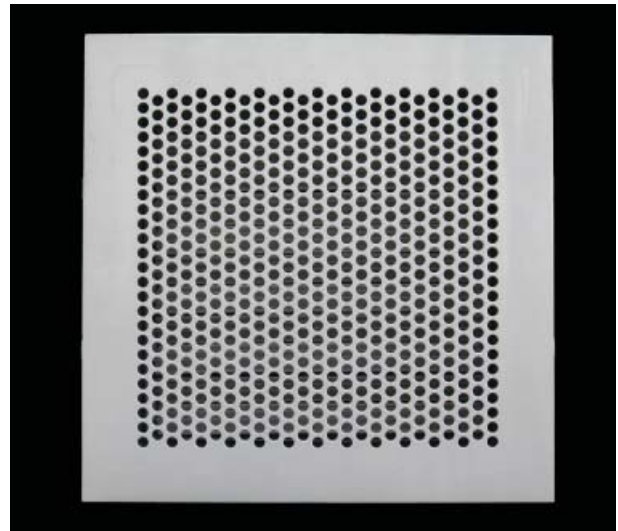



## Maximum Security Perforated Grille

Model: AMPSG

## Air flow data

Neck size in mm									
Area factor in m <sup>2</sup>									
150x150	Cfm	33	44	55	77	88	99	110	121
	M <sup>3</sup> /sec	0.016	0.021	0.026	0.036	0.041	0.047	0.052	0.057
	Face Vel. m/sec	1.5	2.0	2.5	3.5	4.0	4.5	5.0	5.5
0.0748	P <sub>T</sub> in mm H <sub>2</sub> O	0.289	0.531	0.820	1.182	1.592	2.076	2.630	3.257
	Throw in m	1.1-3.7	2.3-4.9	3.1-6.0	3.7-6.6	4.3-7.2	4.9-7.8	5.5-8.1	6.0-8.6
	NC	<15	<15	<15	15	20	22	26	30
200x200	Cfm	64	86	107	128	150	172	193	214
	M <sup>3</sup> /sec	0.030	0.040	0.050	0.060	0.071	0.081	0.091	0.101
	Face Vel. m/sec	1.5	2.0	2.5	3.0	3.5	4.0	4.5	5.0
0.1454	P <sub>T</sub> in mm H <sub>2</sub> O	0.265	0.483	0.748	1.086	1.496	1.930	2.461	3.040
	Throw in m	1.4-4.6	2.6-6.3	4.0-7.8	4.6-8.9	5.5-9.5	6.3-10.4	6.9-11.0	7.8-11.5
	NC	<15	<15	15	18	20	22	25	30
300x300	Cfm	166	221	276	331	386	442	497	552
	M <sup>3</sup> /sec	0.078	0.104	0.130	0.156	0.182	0.209	0.234	0.260
	Face Vel. m/sec	1.5	2.0	2.5	3.0	3.5	4.0	4.5	5.0
0.3724	P <sub>T</sub> in mm H <sub>2</sub> O	0.241	0.434	0.676	0.989	1.327	1.737	2.219	2.726
	Throw in m	2.0-6.6	3.4-8.9	5.5-11.2	6.6-13.3	7.8-14.4	8.9-15.3	10.1-16.5	11.2-17.3
	NC	<15	<15	<15	16	19	24	26	30
450x450	Cfm	284	426	568	712	853	996	1137	1280
	M <sup>3</sup> /sec	0.134	0.201	0.268	0.336	0.403	0.470	0.537	0.604
	Face Vel. m/sec	1.0	1.5	2.0	2.5	3.0	3.5	4.0	4.5
0.9538	P <sub>T</sub> in mm H <sub>2</sub> O	0.217	0.386	0.627	0.893	1.206	1.568	2.0	2.461
	Throw in m	2.6-9.8	4.6-13.0	7.2-16.2	9.8-19.4	11.0-21.7	13.0-23.1	14.7-24.6	16.2-26.0
	NC	<15	<15	16	19	23	27	30	32
500x500	Cfm	365	545	727	908	1090	1270	1453	1635
	M <sup>3</sup> /sec	0.172	0.257	0.343	0.428	0.514	0.599	0.686	0.772
	Face Vel. m/sec	1.0	1.5	2.0	2.5	3.0	3.5	4.0	4.5
1.223	P <sub>T</sub> in mm H <sub>2</sub> O	0.217	0.374	0.603	0.856	1.158	1.520	1.929	2.376
	Throw in m	2.9-11.3	5.1-14.9	8.1-18.7	11.3-22.3	12.9-25.3	14.9-27.0	16.8-28.7	18.7-30.4
	NC	<15	<15	16	18	24	29	32	35
600x600	Cfm	554	835	1113	1390	1667	1944	2225	2502
	M <sup>3</sup> /sec	0.261	0.394	0.525	0.656	0.787	0.917	1.050	1.180
	Face Vel. m/sec	1.0	1.5	2.0	2.5	3.0	3.5	4.0	4.5
1.9266	P <sub>T</sub> in mm H <sub>2</sub> O	0.217	0.362	0.579	0.820	1.110	1.472	1.858	2.292
	Throw in m	3.1-12.7	5.7-16.7	8.9-21.1	12.7-25.1	14.7-28.9	16.7-30.9	18.8-32.7	21.1-34.7
	NC	<15	<15	15	20	25	30	34	38
750x750	Cfm	939	1406	1871	2337	2810	3276	3741	4208
	M <sup>3</sup> /sec	0.443	0.663	0.883	1.103	1.326	1.546	1.766	1.986
	Face Vel. m/sec	1.0	1.5	2.0	2.5	3.0	3.5	4.0	4.5
3.184	P <sub>T</sub> in mm H <sub>2</sub> O	0.217	0.302	0.509	0.715	1.090	1.372	1.768	2.182
	Throw in m	3.6-14.9	6.7-19.6	10.4-24.8	14.9-29.5	17.2-34.0	19.6-36.3	22.1-38.5	25.0-40.8
	NC	<15	<15	16	22	27	31	35	40

- Neck size measured in mm.
- P<sub>T</sub> - Total pressure loss is in mm of H<sub>2</sub>O.
- Throw (meters) is measured for a terminal velocities of 0.5 & 0.25 m/sec.
- Noise criteria (NC) is based on a room attenuation of 10dB.



## Floor Grille - Light Duty

Model: AFG-L

### Construction:

- **Frame:** Heavy gauge high quality extruded aluminium profile.
- **Face bars:** 6mm thick high quality aluminium bars with 12mm pitch.

### Description:

- Frame is constructed of high quality extruded aluminium profile with the advantages of corrosion resistance and rigidity.
- Structure is robustly constructed with face bars positioned in the frame.
- Face bars assembly is supported by heavy duty aluminium round rod.
- Applicable for installation in gymnasium, sport halls, hospitals and computer rooms.
- Suitable for sill level applications on edges of walkways, passages or raised platforms. Can be supplied in 0° deflection, 15° or 30° one way deflection.

### Standard finishes:

- Powder coated as per RAL color codes.

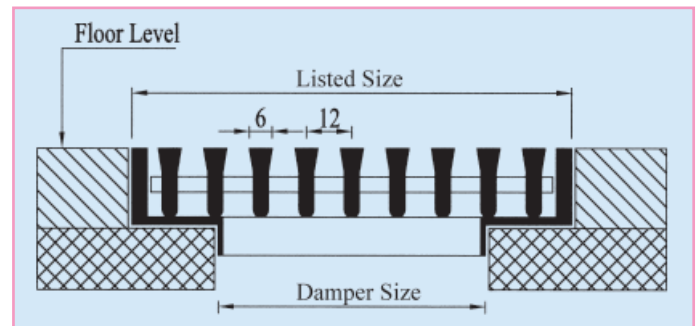
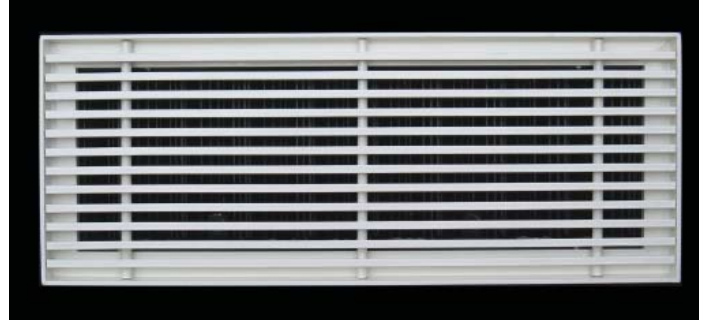



air master

# Floor Grille - Light Duty

► Model: AFG-L

Width in mm	Face Velocity in m/sec	2.0	2.5	3.0	3.5	4.0	4.5	5.0
$A_f$ in m <sup>2</sup>								
50	Cfm	89	111	133	156	178	200	222
	M <sup>3</sup> /sec	0.042	0.053	0.063	0.074	0.084	0.095	0.105
	P <sub>s</sub> in mm H <sub>2</sub> O	0.23	0.31	0.52	0.68	0.83	1.18	1.48
0.021	Throw in m	0.5-0.7	0.6-1.1	0.7-1.3	0.9-2.1	1.3-2.5	1.6-3.1	2.2-3.8
	NC	<20	20	22	25	27	29	30
100	Cfm	225	281	337	393	449	505	561
	M <sup>3</sup> /sec	0.106	0.133	0.159	0.186	0.212	0.239	0.265
	P <sub>s</sub> in mm H <sub>2</sub> O	0.23	0.31	0.52	0.68	0.83	1.18	1.48
0.053	Throw in m	0.7-1.3	1.3-2.8	2.3-4.1	2.5-4.8	2.8-5.4	3.5-6.4	4.1-7.3
	NC	<20	20	25	28	30	32	35
150	Cfm	347	434	521	608	695	782	868
	M <sup>3</sup> /sec	0.164	0.205	0.246	0.287	0.328	0.369	0.41
	P <sub>s</sub> in mm H <sub>2</sub> O	0.23	0.31	0.52	0.68	0.83	1.18	1.48
0.082	Throw in m	0.8-1.6	1.5-3.1	2.4-4.5	2.7-5.1	3.3-6.1	4.1-6.9	4.4-7.8
	NC	<20	20	25	27	30	33	35
200	Cfm	483	604	724	845	966	1087	1207
	M <sup>3</sup> /sec	0.228	0.285	0.342	0.399	0.456	0.513	0.57
	P <sub>s</sub> in mm H <sub>2</sub> O	0.23	0.31	0.52	0.68	0.83	1.18	1.48
0.114	Throw in m	0.9-1.8	1.7-3.7	2.5-4.8	3.1-5.4	3.5-6.7	4.4-7.3	4.9-8.2
	NC	<20	20	25	28	31	33	35
250	Cfm	602	752	902	1053	1203	1353	1504
	M <sup>3</sup> /sec	0.284	0.355	0.426	0.497	0.568	0.639	0.71
	P <sub>s</sub> in mm H <sub>2</sub> O	0.23	0.31	0.52	0.68	0.83	1.18	1.48
0.142	Throw in m	1.1-2.1	1.8-4.1	2.7-4.9	3.2-5.7	3.7-6.9	4.5-7.2	5.1-8.3
	NC	<20	20	25	27	30	32	35
300	Cfm	724	905	1087	1268	1449	1630	1811
	M <sup>3</sup> /sec	0.342	0.428	0.513	0.598	0.684	0.77	0.855
	P <sub>s</sub> in mm H <sub>2</sub> O	0.23	0.31	0.52	0.68	0.83	1.18	1.48
0.171	Throw in m	1.2-2.2	1.8-4.2	2.6-4.9	3.0-5.5	3.6-6.8	4.5-7.1	4.9-8.2
	NC	<20	20	25	28	31	33	35

- Data based on one meter unit length of the grille with damper in full open position.
- Face velocity is measured in m/sec.
- P<sub>s</sub> - Static pressure loss is in mm of H<sub>2</sub>O.
- Throw (meters) is measured for a terminal velocities of 0.5 & 0.25 m/sec.
- Noise criteria (NC) based on a room attenuation of 10dB.



# Floor Grille - Heavy Duty

Model: AFG-H

### Construction:

- **Frame:** Heavy gauge high quality extruded aluminium profile 4mm thick, flange width 40mm.
- **Face bars:** 60mm high "I" section made up of high quality extruded aluminium.

### Description:

- Frame is constructed of high quality extruded aluminium profile with the advantages of corrosion resistance and rigidity.
- Structure is robustly constructed with face bars positioned in the frame.
- Face bars assembly is reinforced with steel rods to withstand heavy loads.
- Applicable for installation in gymnasium, sport halls, hospitals and computer rooms.
- A recess of 40mmx4mm has to be provided around the grille, in the floor to install the grill flush with the floor (or) carpet level.

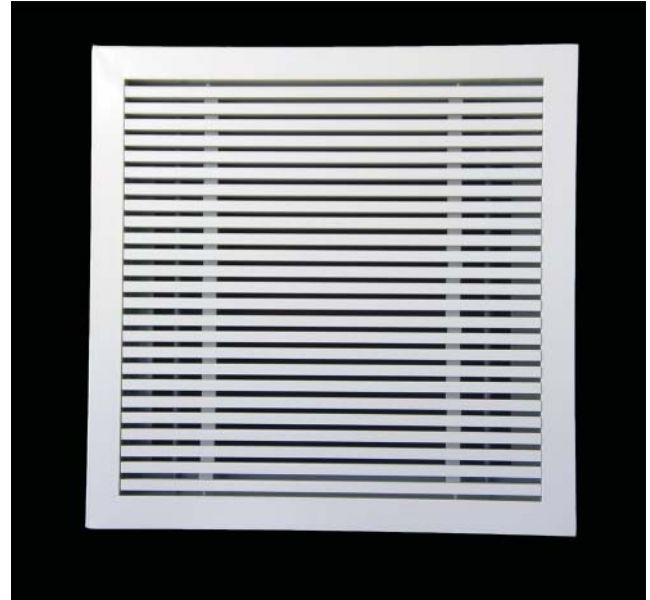

### Standard finishes:

- Powder coated as per RAL color codes.

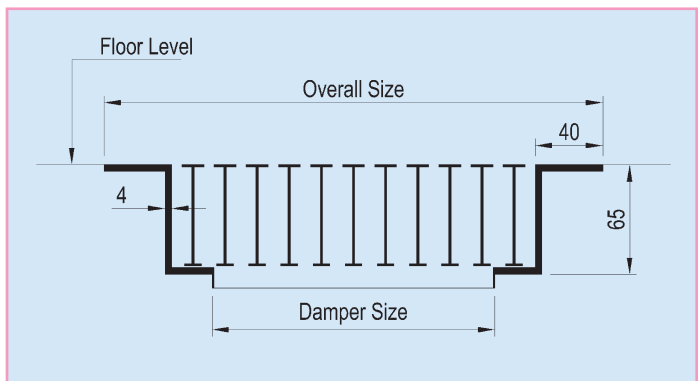

### Grille Size 600x600mm (Overall Size)

<b>Air Flow in CFM</b>	<b>192</b>	<b>383</b>	<b>424</b>	<b>574</b>	<b>766</b>	<b>957</b>	<b>1149</b>	<b>1340</b>
<b>Air Flow in m<sup>3</sup>/sec</b>	<b>0.091</b>	<b>0.181</b>	<b>0.200</b>	<b>0.271</b>	<b>0.362</b>	<b>0.452</b>	<b>0.542</b>	<b>0.632</b>
<b>Neck velocity in m/s</b>	0.96	1.9	2.1	2.9	3.8	4.8	5.7	6.7
<b>Pressure drop in mm of H<sub>2</sub>O</b>	0.123	0.360	0.480	0.603	0.960	1.55	2.29	3.00
<b>Throw in meters</b>	2.1	2.8	2.9	4.2	5.9	7.5	9.2	10.6
<b>NC</b>	<15	<20	20	25	29	31	33	34

- Data based on 600x600mm Grille.
- Face velocity is measured in m/sec.
- Noise criteria (NC) is based on room attenuation of 10db.