



# Chapter 2

# INDEX

## A. Grilles and registers.

1. Supply air grille - front horizontal blades.....	ASG-H.....	2.1
2. Supply air grille - front vertical blades.....	ASG-V.....	2.2
3. Supply air register - front horizontal blades..:	ASR-H.....	2.3
4. Supply air register - front vertical blades.....	ASR-V.....	2.4
5. Return air grille - fixed horizontal blades.....	ARG-H.....	2.5
6. Return air grille - vertical blades.....	ARG-V.....	2.6
7. Return air grille - horizontal blades.....	ARG-HA.....	2.7
8. Fresh air grille.....	AFG.....	2.8
• Mullion arrangement.....		2.9
• Standard sizes.....		2.9
• Fixing details.....		2.10
• How to order.....		2.10

## B. Air flow data.

1. Supply air grilles and registers.....	Tab 2.1.....	2.11
Models: ASG-H, ASG-V, ASR-H, ASR-V		
2. Return air grille - Fixed horizontal blades....:	Tab 2.2.....	2.15
Model: ARG-H		
3. Return air grilles and registers.....	Tab 2.3.....	2.16
Models: ARG-V, ARG-HA, ARR-V, ARR-HA		





air master

# Supply air grille

– front horizontal

► Model: ASG-H

## Construction:

- **Frame:** High quality extruded aluminium profile with 30 mm flange width as standard. 12, 16, 24 mm flange widths are optional.
- **Blades:** Aerofoil blades from aluminium profiles.
- **Blade spacing:** 20 mm as standard.

## Description:

- The frame and blades are of high quality extruded aluminum profiled construction with the advantages of corrosion resistance and rigidity.
- Grilles have two sets parallel aerofoil blades with one set mounted horizontally on the front and other set vertically at the rear.
- Frame is separated from aerofoil deflection blades by nylon bushings. This method of assembly ensures quiet, smooth and rattle free operation.
- Deflection blades can be adjusted manually and individually, to provide air deflection in both horizontal and vertical planes.
- Maximum effective pressure areas can be achieved when the blades are positioned at 0° position.
- Foam gasket is sealed around the back of the frame as option to avoid air leakage.



## Standard finishes:

- Natural anodized aluminum finish.
- Powder coated colour finish as per RAL colour codes.
- Flexibility of finishing available on request.

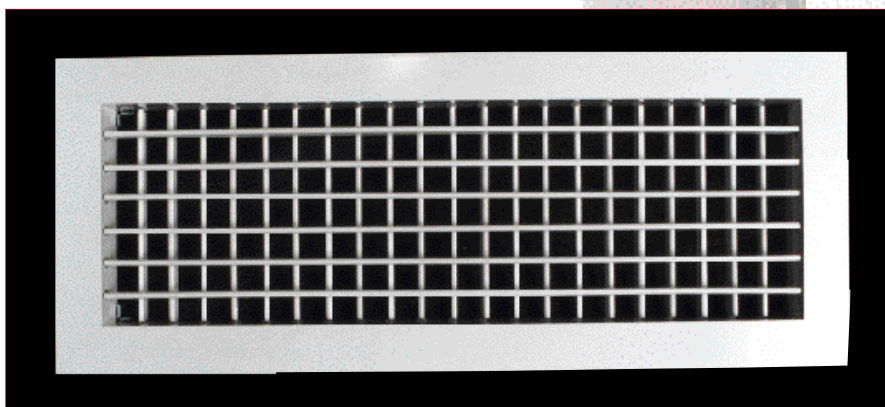
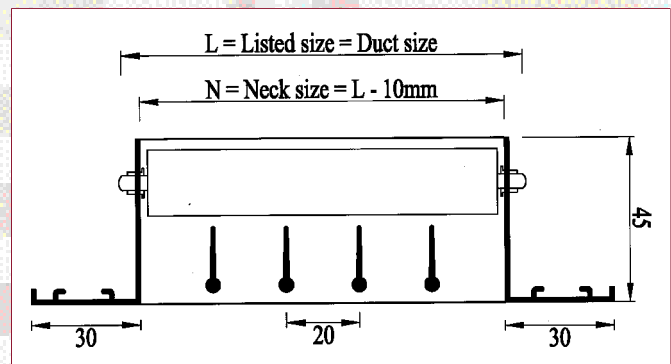



# air master

## Supply air grille

– front vertical

► Model: ASG-V

### Construction:

- **Frame:** High quality extruded aluminium profile with 30 mm flange width as standard. 12, 16, 24 mm flange widths are optional.
- **Blades:** Aerofoil blades from aluminium profiles.
- **Blade spacing:** 20 mm as standard.

### Description:

- The frame and blades are of high quality extruded aluminum profiled construction with the advantage of corrosion resistance and rigidity.
- Grilles have two sets parallel aerofoil blades with one set mounted vertically on the front and other set horizontally at the rear.
- Frame is separated from aerofoil deflection blades with nylon bushings. This method of assembly ensures quiet, smooth and rattle free operation.
- Deflection blades can be adjusted manually and individually, to provide air distribution in both vertical and horizontal planes.
- Maximum effective pressure areas can be achieved when the blades are positioned at 0° position.
- Foam gasket is sealed around the back of the frame as option to avoid air leakage.



### Standard finishes:

- Natural anodized aluminum finish.
- Powder coated colour finish as per RAL colour codes.
- Flexibility of finishing available on request.

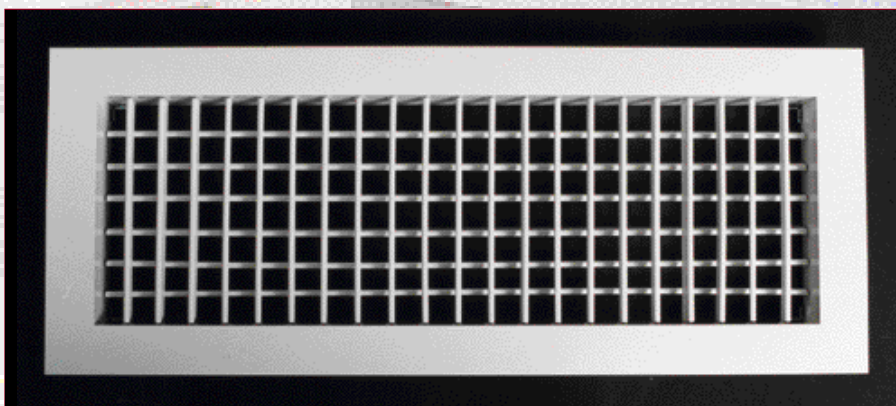
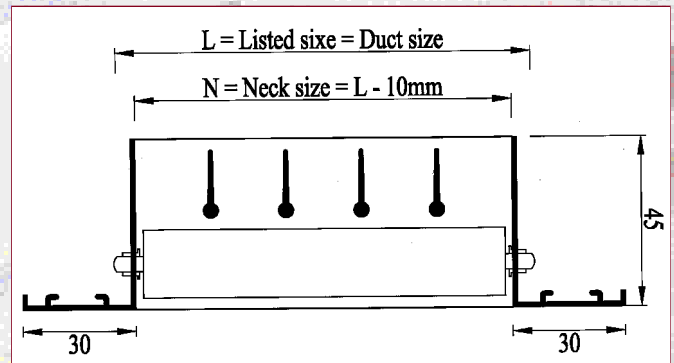



air master

# Supply air register

– front horizontal

► Model: ASR-H

## Construction:

- **Frame:** High quality extruded aluminium profile with 30 mm flange width as standard. 12, 16, 24 mm flange widths are optional.
- **Blades:** Aerofoil blades from aluminium profiles.
- **Blade spacing:** 20 mm as standard.
- **Damper frame and blades:** High quality extruded aluminium profiles with natural aluminium finish. Black matt finish as option.

## Description:

- The frame and blades are of high quality extruded aluminum profiled construction with the advantages of corrosion resistance and rigidity.
- Grilles have two sets parallel aerofoil blades with one set mounted horizontally on the front and other set vertically at the rear.
- Frame is separated from aerofoil deflection blades by nylon bushings. This method of assembly ensures quiet, smooth and rattle free operation.
- Deflection blades can be adjusted manually and individually, to provide air deflection in both horizontal and vertical planes.
- Grilles are rigidly fixed with opposed blade damper by grippers. Damper blade is screw operated from the face opening.



- Foam gasket is sealed around the back of the frame as option to avoid air leakage.

## Standard finishes:

- Natural anodized aluminum finish.
- Powder coated colour finish as per RAL colour codes.
- Flexibility of finishing available on request.

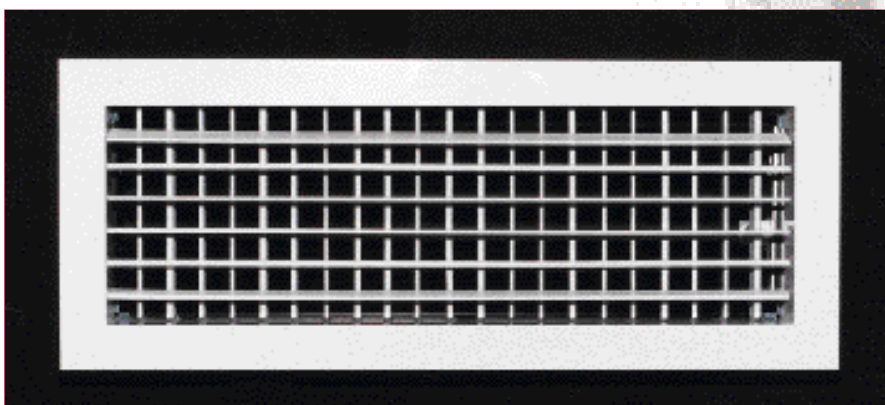
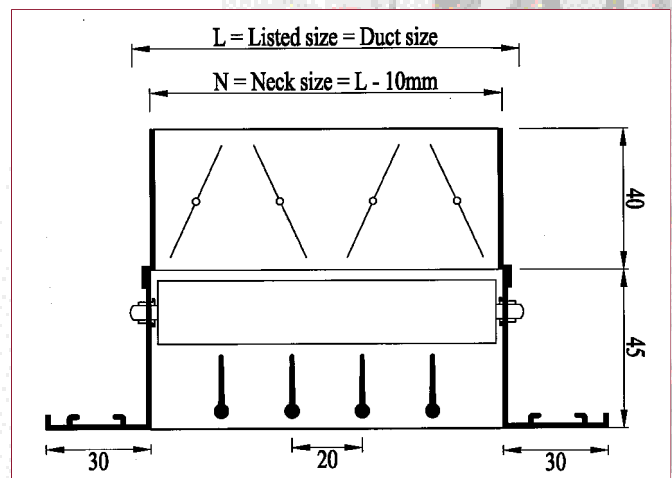



# air master

## Supply air register

– front vertical

► Model: ASR-V

### Construction:

- **Frame:** High quality extruded aluminium profile with 30 mm flange width as standard. 12, 16, 24 mm flange widths are optional.
- **Blades:** Aerofoil blades from aluminium profiles.
- **Blade spacing:** 20 mm as standard.
- **Damper frame and blades:** High quality extruded aluminium profiles with natural aluminium finish. Black matt finish as option.

### Description:

- The frame and blades are of high quality extruded aluminum profiled construction with the advantages of corrosion resistance and rigidity.
- Grilles have two sets parallel aerofoil blades with one set mounted vertically on the front and other set horizontally at the rear.
- Frame is separated from aerofoil deflection blades by nylon bushings. This method of assembly ensures quiet, smooth and rattle free operation.
- Deflection blades can be adjusted manually and individually to provide air deflection in both horizontal and vertical planes.
- Grilles are rigidly fixed with opposed blade damper by grippers. Damper blade is screw operated from the face opening.



- Foam gasket is sealed around the back of the frame as option to avoid air leakage.

### Standard finishes:

- Natural anodized aluminum finish.
- Powder coated colour finish as per RAL colour codes.
- Flexibility of finishing available on request.

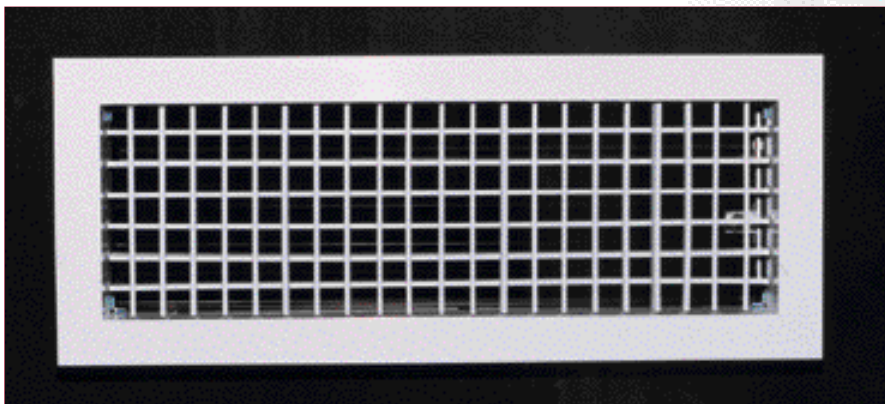
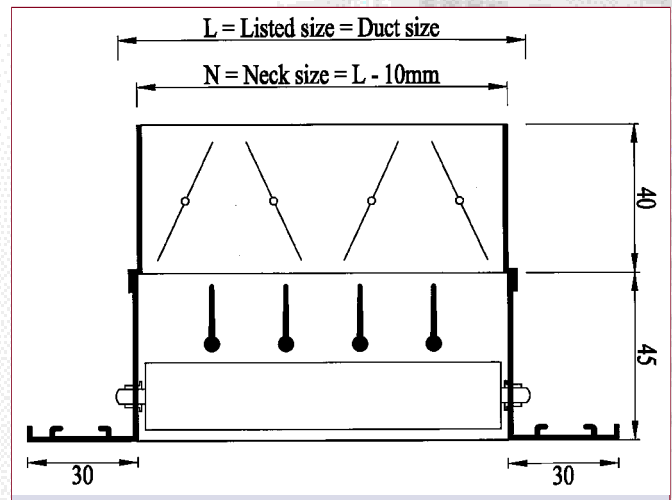



air master

# Return air grille

– fixed horizontal blades

► Model: ARG-H

## Construction:

- **Frame:** High quality extruded aluminium profile with 30 mm flange width as standard. 12, 16, 24 mm flange widths are optional.
- **Blades:** Aerofoil blades from aluminium profiles.
- **Blade spacing:** 20 mm as standard.

## Description:

- The frame and blades are of high quality extruded aluminum profiled construction with the advantages of corrosion resistance and rigidity.
- Deflection blades are fixed rigidly to the frame at an angle of  $45^{\circ}$  to the horizontal plane.
- Foam gasket is sealed around the back of the frame as option to avoid air leakage.

## Standard finishes:

- Natural anodized aluminum finish.
- Powder coated colour finish as per RAL colour codes.
- Flexibility of finishing available on request.



**Model: ARR-H:** Return air register with fixed horizontal blades. Construction is same as ARG-H, with opposed blade damper.

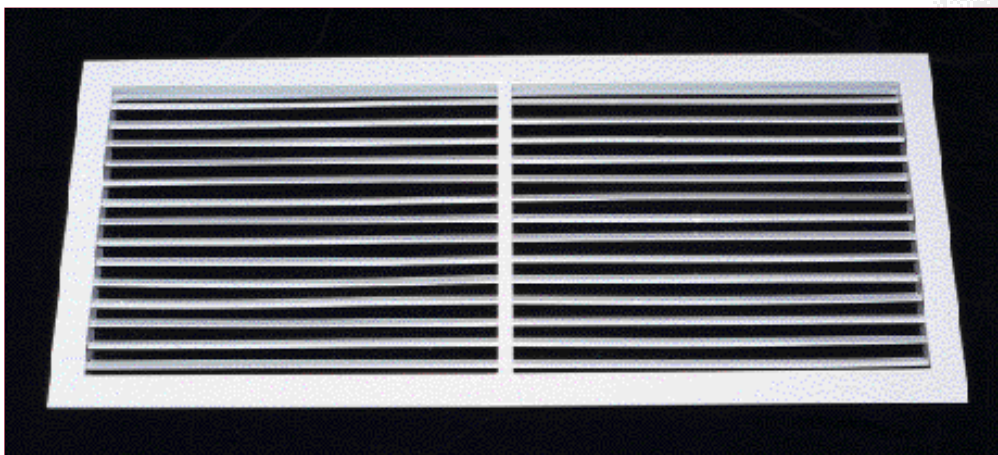
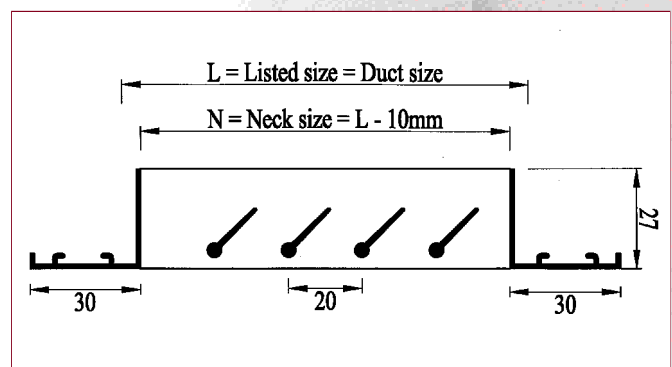



air master

# Return air grille

– vertical blades

► Model: ARG-V

## Construction:

- **Frame:** High quality extruded aluminium profile with 30 mm flange width as standard. 12, 16, 24 mm flange widths are optional.
- **Blades:** Aerofoil blades from aluminium profiles.
- **Blade spacing:** 20 mm as standard.

## Description:

- The frame and blades are of high quality extruded aluminum profiled construction with the advantages of corrosion resistance and rigidity.
- Frame is separated from the aerofoil deflection blades with nylon bushings. This method of assembly assures quiet, smooth and rattle free operation.
- Deflection blades can be adjusted manually and individually in the vertical plane to obtain optimum air distribution.
- Maximum effective pressure areas can be achieved when the blades are positioned at 0° vertical position.
- Foam gasket is sealed around the back of the frame as option to avoid air leakage.

## Standard finishes:

- Natural anodized aluminum finish.



- Powder coated colour finish as per RAL colour codes.
- Flexibility of finishing available on request.

**Model: ARR-V:** Return air register with vertical blades. Construction is same as ARG-V, with opposed blade damper.

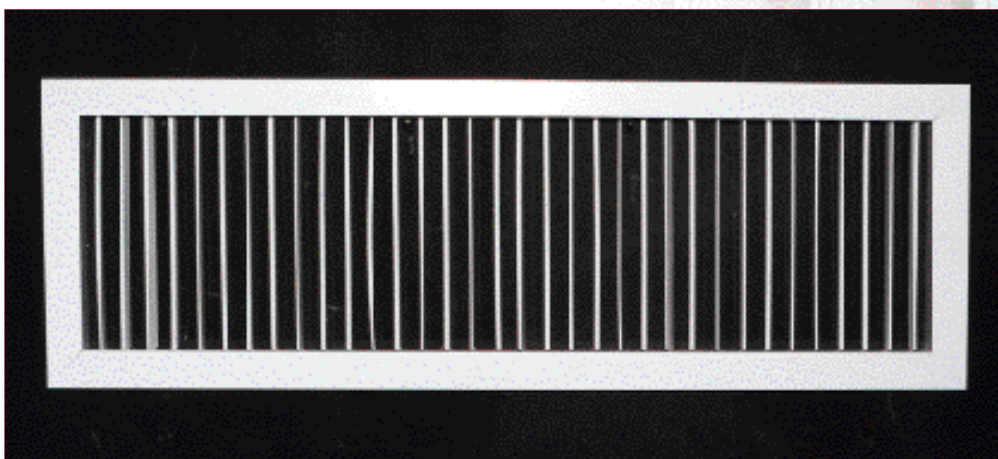
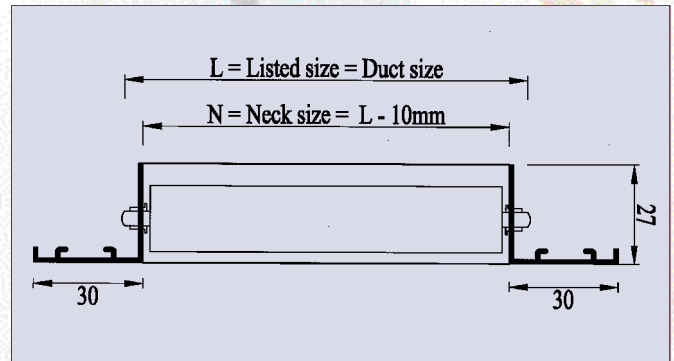



air master

# Return air grille

– adjustable horizontal blades

► Model: ARG-HA

## Construction:

- **Frame:** High quality extruded aluminium profile with 30 mm flange width as option. 12, 16, 24 mm flange widths are optional.
- **Blades:** Aerofoil blades from aluminium profiles.
- **Blade spacing:** 20 mm as standard.

## Description:

- The frame and blades are of high quality extruded aluminum profiled construction with the advantages of corrosion resistance and rigidity.
- Frame is separated from the aerofoil deflection blades with nylon bushings. This method of assembly assures quiet, smooth and rattle free operation.
- Deflection blades can be adjusted manually and individually in the horizontal plane to obtain optimum air distribution.
- Maximum effective pressure areas can be achieved when the blades are positioned at 0° horizontal position.
- Foam gasket is sealed around the back of the frame as option to avoid air leakage.



## Standard finishes:

- Natural anodized aluminum finish.
- Powder coated colour finish as per RAL colour codes.
- Flexibility of finishing available on request.

**Model: ARR-HA:** Return air register with adjustable horizontal blades. Construction is same as ARG-HA, with opposed blade damper.

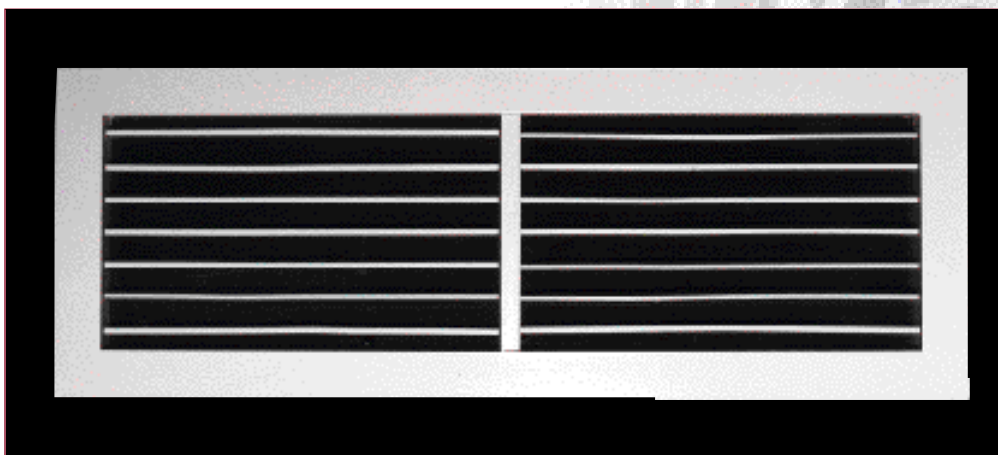
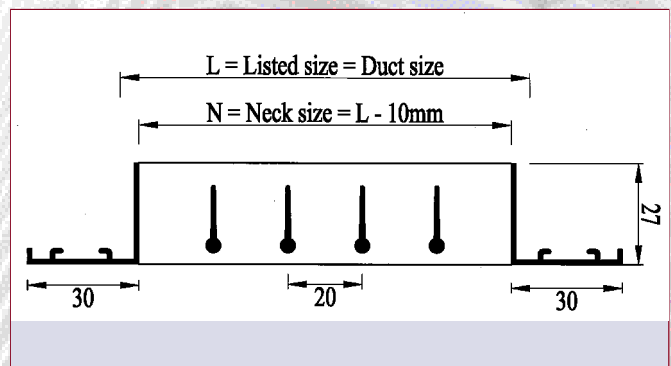



air master

# Fresh air grille

Model: AFAG

## Construction:

- **Frame:** High quality extruded aluminium profile with 30 mm flange width as standard. 12, 16, 24 mm flange widths are optional.
- **Blades:** Aerofoil blades from aluminium profiles.
- **Blade spacing:** 20 mm as standard.
- **Filter frame:** One mm thick aluminium sheet.
- **Filter media:** Aluminium mesh.

## Description:

- The frame and blades are of high quality extruded aluminum profiled construction with the advantages of corrosion resistance and rigidity.
- Deflection blades are fixed rigidly to the frame at an angle of 45° to the horizontal plane.
- Removable 12 mm thick aluminium washable filter is placed at the back of the grille.
- Grille frame is fixed to the main frame by hinges on one side and by screw on the other side.
- Filter can be removed easily by opening the grille frame.
- Total assembly will be same as ARG-H, with removable 12 mm thick aluminium filter.
- Foam gasket is sealed around the back of the frame as option to avoid air leakage.

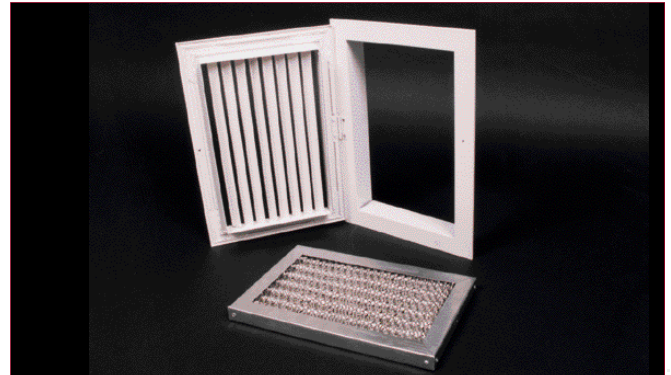

## Standard finishes:

- Natural anodized aluminum finish.
- Powder coated colour finish as per RAL colour codes.
- Flexibility of finishing available on request.

**Model: AFAR :** Fresh air register with fixed horizontal blades. Construction is same as AFAG, with opposed blade damper.

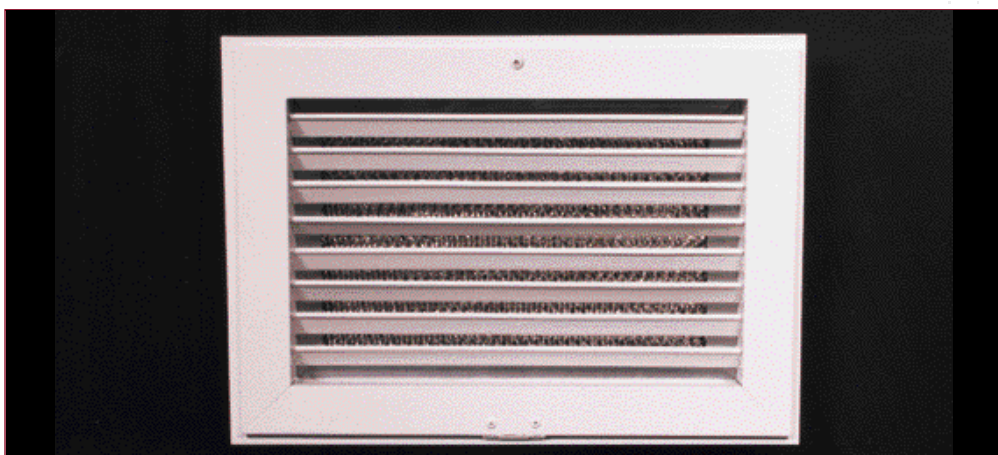
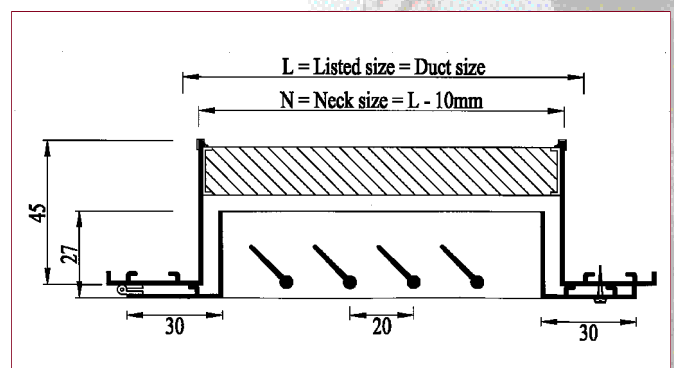



# Universal Grille

Model: AUG

## Construction:

- **Frame:** High quality extruded aluminium profile with 30 mm flange width as standard. 24 mm flange width as optional.
- **Blades:** Aerofoil blades from aluminium profiles.
- **Blade spacing:** 20 mm as standard.
- **Damper frame and blades:** High quality extruded aluminium profiles with natural aluminium finish. Black matt finish as option.

## Description:

- This grille is specifically designed for direct mounting on rigid round duct, with a curved face.
- The frame and blades are of high quality extruded aluminium profiled construction with the advantages of corrosion resistance and rigidity.
- Grilles have two sets of parallel aerofoil blades with one set mounted horizontally on the front and other set vertically at the rear.
- Frame is separated from the aerofoil deflection blades by nylon bushings. This method of assembly ensures quiet, smooth and rattle free operation.
- Deflection blades can be adjusted manually and individually, to provide air deflection in both horizontal and vertical planes.
- Grilles are rigidly fixed with opposed blade damper by grippers. Damper blade is screw operated from the face opening.

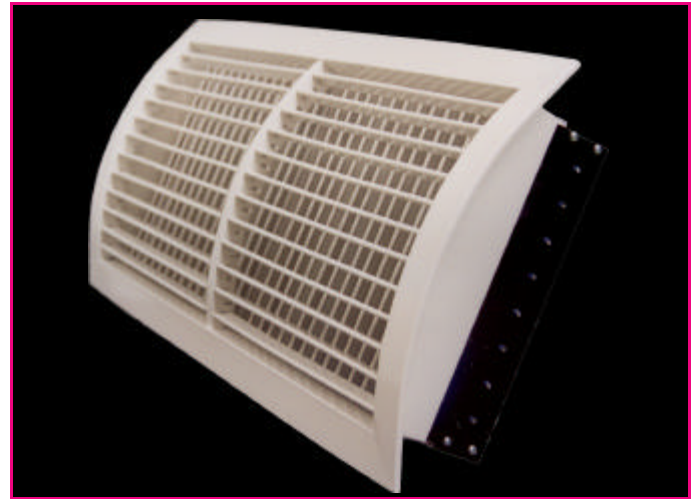

- Foam gasket is sealed around the back of the frame as option to avoid air leakage.

## Standard finishes:

- Natural anodized aluminium finish.
- Powder coated color finish as per RAL color codes.
- Flexibility of finishing available on request.

## Air flow data:

The datas can be taken from the table 2.1 provided for normal grilles.

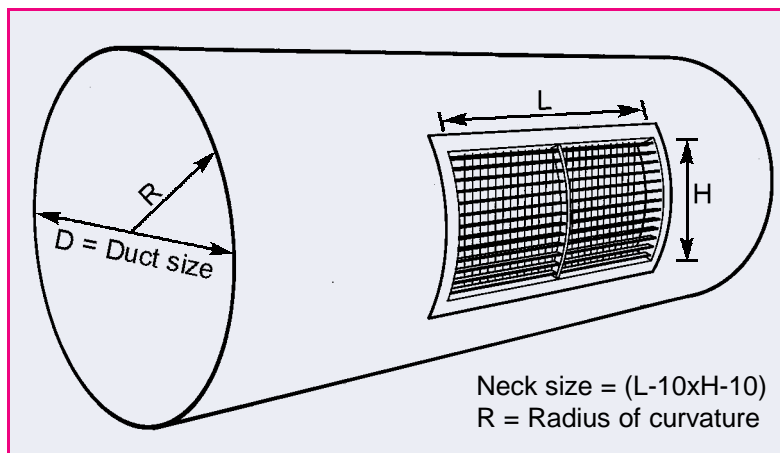



**air master**

**Mullion arrangement:**

- **Mullion:** Aluminium profiled U-channel.
- If the length of the grille is above 500 mm, horizontal aerofoil blades are connected through a mullion, fixed at the centre of the grille for stability.
- For grilles of length 1000mm and above, two mullions will be connected vertically at equidistant.

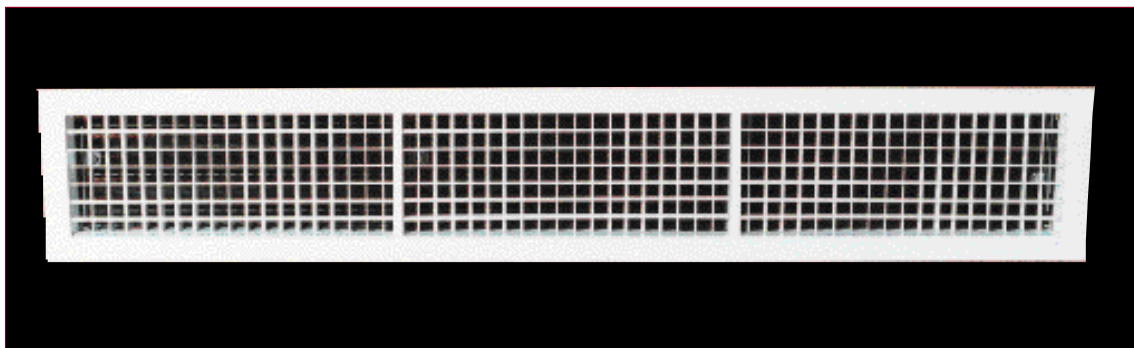

**Standard sizes:**

- Available in square and rectangular sizes.
- All combination of W x H.
- Non standard sizes are available as option.

W x H mm x mm	W x H mm x mm	W x H mm x mm	W x H mm x mm	W x H mm x mm
150 x 150	300 x 200	400 x 150	500 x 150	650 x 100
200 x 100	300 x 250	400 x 200	500 x 200	700 x 250
200 x 125	300 x 300	400 x 250	500 x 250	750 x 100
200 x 150	350 x 125	400 x 300	500 x 300	750 x 150
250 x 100	350 x 150	400 x 400	500 x 350	750 x 200
250 x 125	350 x 200	450 x 100	500 x 400	750 x 250
250 x 150	350 x 250	450 x 150	600 x 125	900 x 150
250 x 200	350 x 300	450 x 200	600 x 150	900 x 200
250 x 250	350 x 350	450 x 450	600 x 200	1000 x 200
300 x 100	400 x 100	500 x 100	600 x 250	1200 x 150
300 x 125	400 x 125	500 x 125	600 x 300	



# air master

## Fixing details:

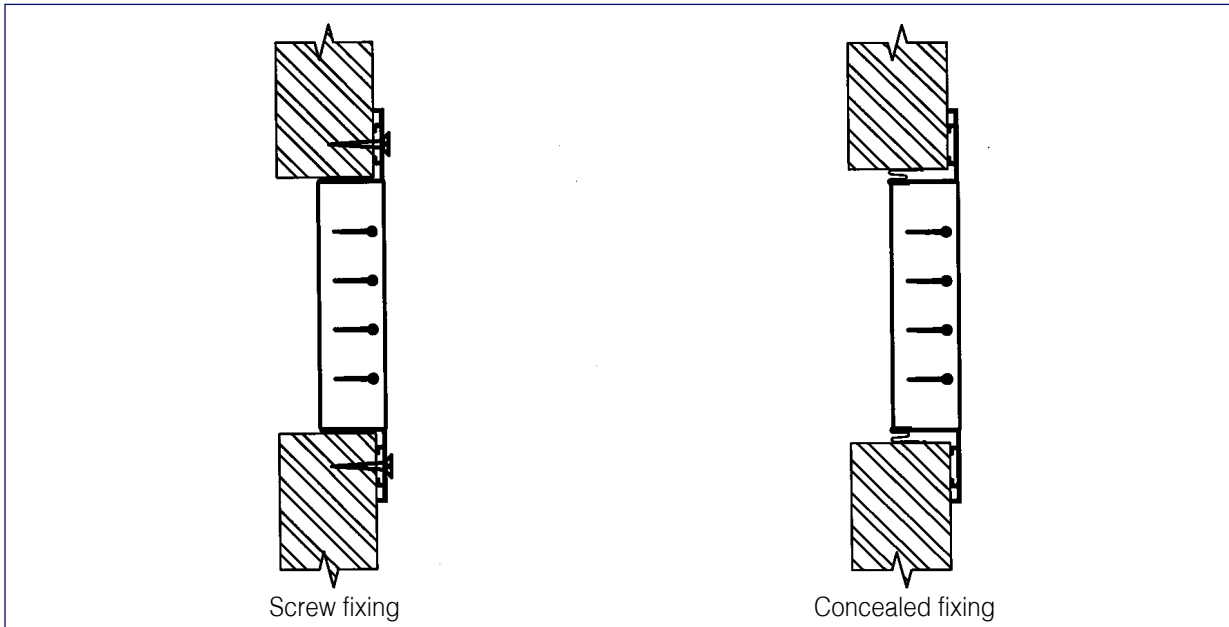

## How to order:

Model	Aerofoil blades	Size	Quantity	Finish
ASG	H = Front horizontal	Specify listed size Length x heigh in mm x mm	Specify in numbers	A = Aluminium anodized finish
ASR				B = RAL 9010
ARG	V = Front vertical			C = Other RAL colours
ARR				

Tick the required item.

## Ordering example:

- To select supply air register, front horizontal aerofoil blades of size 600 x 150 mm, Qty = 60 nos, with RAL-9010 colour finish.

**Order as:** ASR - H - 600 x 150 - 60 - B.



air master

# Supply air grilles and registers

Rating with 0° and 45° deflection

Models: ASG-H, ASG-V, ASR-H, ASR-V

**Table 2.1 Air flow data**

CFM	Listed Size in mm x mm	200 x 100		250 x 100 200 x 125 150 x 150		200 x 150 250 x 125 300 x 100		250 x 150 300 x 125 400 x 100		300 x 150 350 x 125 450 x 100		
		M <sup>3</sup> /sec	Area factor Deflection	0°	45°	0°	45°	0°	45°	0°	45°	0°
100	Face vel P <sub>t</sub> mm H <sub>2</sub> O Throw in (M) N.C	0.0472	2.47 0.43 4.2-5.4 15	5.08 1.45 2.7-4.8 19	2.37 0.35 3.9-5.5 <15	4.63 1.22 3.0-4.9 16	2.21 0.33 3.9-5.2 <15	4.18 1.04 3.0-4.9 <15	1.92 0.23 4.0-5.2 <15	3.32 0.69 2.7-4.6 <15		
150	Face vel P <sub>t</sub> mm H <sub>2</sub> O Throw in (M) N.C	0.0708	3.71 0.99 4.9-6.4 18	7.61 3.23 3.6-5.8 24	3.56 0.78 4.6-6.1 16	6.94 2.72 3.7-5.5 21	3.31 0.74 4.3-6.1 <15	6.27 2.31 3.7-5.2 16	2.87 0.53 4.3-6.1 <15	4.98 1.55 3.4-5.2 <15	2.63 0.46 4.0-5.8 <15	4.19 1.07 3.4-4.9 <15
200	Face vel P <sub>t</sub> mm H <sub>2</sub> O Throw in (M) N.C	0.0945	4.95 1.77 5.2-7.3 21	10.16 5.76 4.3-6.4 28	4.75 1.39 5.2-7.0 19	9.26 4.88 4.3-6.1 25	4.42 1.3 4.9-7.0 17	8.36 4.12 3.9-6.1 24	3.84 0.94 4.9-6.7 15	6.65 2.77 4.0-5.8 20	3.51 0.81 4.6-6.7 <15	5.59 1.88 4.0-5.8 15
250	Face vel P <sub>t</sub> mm H <sub>2</sub> O Throw in (M) N.C	0.1181	6.18 2.76 5.8-7.9 28	12.69 9.02 4.8-7.0 35	5.93 2.18 5.8-7.9 27	11.58 7.62 4.9-7.0 32	5.52 2.0 5.5-7.6 24	10.45 6.45 4.9-6.7 31	4.80 1.45 5.4-7.6 21	8.32 4.32 4.6-6.7 27	4.39 1.24 5.2-7.6 17	6.988 2.95 4.6-6.7 23
300	Face vel P <sub>t</sub> mm H <sub>2</sub> O Throw in (M) N.C	0.1417	7.42 3.96 5.8-8.2 34	15.24 13.21 5.2-7.3 40	7.12 3.15 5.8-8.2 31	13.89 10.92 5.2-7.3 38	6.62 2.9 5.8-8.2 28	12.54 9.27 5.2-7.3 36	5.76 2.1 5.8-8.2 26	9.98 6.22 5.2-7.3 33	5.27 1.8 5.8-8.2 23	8.38 4.24 5.2-7.3 30
350	Face vel P <sub>t</sub> mm H <sub>2</sub> O Throw in (M) N.C	0.1653	8.65 5.38 7.0-9.8 37	17.77 17.53 5.8-8.2 45	8.31 4.32 6.7-9.5 35	16.21 14.98 5.8-8.2 42	7.72 3.9 6.7-9.5 32	14.63 12.57 5.4-7.9 39	6.72 2.87 6.4-9.2 30	11.64 8.51 5.4-7.9 37	6.14 2.46 6.4-9.1 28	9.78 5.77 5.4-7.9 35
400	Face vel P <sub>t</sub> mm H <sub>2</sub> O Throw in (M) N.C	0.1889			9.49 5.61 7.6-10.4 38	18.52 19.56 6.7-9.1 45	8.83 5.13 7.3-10.4 36	16.72 16.51 6.4-8.8 42	7.68 3.76 7.0-10.1 34	13.30 11.05 6.1-8.5 40	7.022 3.2 6.7-9.8 32	11.18 7.52 6.1-8.5 38
450	Face vel P <sub>t</sub> mm H <sub>2</sub> O Throw in (M) N.C	0.2125							8.64 4.72 7.3-10.7 39	14.96 13.97 6.7-9.1 43	7.899 4.06 7.0-10.4 36	12.57 9.53 6.4-8.8 42
500	Face vel P <sub>t</sub> mm H <sub>2</sub> O Throw in (M) N.C	0.2362									8.78 5.00 7.3-10.9 40	13.97 11.74 6.7-7.4 45

- Face velocity is measured in m/sec.
- Total pressure loss is in mm of H<sub>2</sub>O & Area factor in square meter.
- Throw (meters) is measured for a terminal velocity of 0.5 and 0.25 m/sec.
- NC based on a room attenuation of 10 dB.



air master

# Supply air grilles and registers

Rating with 0° and 45° deflection

Models: ASG-H, ASG-V, ASR-H, ASR-V

**Table 2.1 (Cont.) Air flow data**

CFM M <sup>3</sup> /sec	Listed Size in mm x mm	250 x 200 350 x 150 400 x 125 500 x 100		250 x 250 300 x 200 400 x 150 500 x 125 650 x 100		300 x 250 450 x 175 500 x 150 600 x 125 750 x 100		300 x 300 350 x 250 450 x 200 600 x 150		350 x 300 400 x 250 500 x 200 750 x 150	
		Area factor	Deflection	0°	45°	0°	45°	0°	45°	0°	45°
200 0.0945	Face vel P <sub>t</sub> mm H <sub>2</sub> O Throw in (M) N.C	3.38 0.64 4.5-6.7 <15	5.31 1.7 3.7-5.8 <15	2.91 0.36 4.5-6.7 <15	4.30 1.17 3.7-5.5 <15	2.42 0.23 4.6-6.7 <15	3.28 0.71 3.4-5.5 <15	2.0 0.15 4.6-6.7 <15	2.56 0.41 3.1-5.5 <15		
250 0.1181	Face vel P <sub>t</sub> mm H <sub>2</sub> O Throw in (M) N.C	4.22 0.99 5.2-7.6 15	6.63 2.64 4.6-6.7 21	3.65 0.58 5.2-7.6 <15	5.37 1.83 4.3-6.7 18	3.03 0.36 5.2-7.6 <15	4.1 1.12 4.3-6.4 <15	2.52 0.23 5.2-7.6 <15	3.201 0.61 3.9-6.4 <15	2.24 0.18 5.2-7.3 <15	2.79 0.41 3.6-6.0 <15
300 0.1417	Face vel P <sub>t</sub> mm H <sub>2</sub> O Throw in (M) N.C	5.06 1.42 5.8-8.2 20	7.96 3.81 5.2-7.3 27	4.37 0.84 5.8-8.2 17	6.44 2.62 5.2-7.3 22	3.63 0.51 5.8-8.2 <15	4.92 1.6 4.8-7.3 19	3.02 0.33 5.8-8.2 <15	3.84 0.89 4.8-7.3 <15	2.68 0.25 5.5-7.9 <15	3.36 0.58 4.9-7.0 <15
400 0.1889	Face vel P <sub>t</sub> mm H <sub>2</sub> O Throw in (M) N.C	6.75 2.51 6.7-9.8 29	10.6 6.73 6.4-8.8 36	5.83 1.47 6.7-9.8 24	8.59 4.67 6.1-8.5 27	4.84 0.91 6.7-9.8 19	6.56 2.87 5.8-8.5 21	4.03 0.61 6.7-9.5 <15	5.19 1.6 5.8-8.2 17	3.58 0.46 6.7-9.5 <15	4.47 1.07 5.5-8.2 <15
500 0.2362	Face vel P <sub>t</sub> mm H <sub>2</sub> O Throw in (M) N.C	8.44 3.91 7.3-10.9 35	13.27 10.54 6.7-9.2 42	7.29 2.28 7.3-10.9 30	10.74 7.24 6.7-9.1 32	6.06 1.45 7.6-11.0 26	8.2 4.47 6.4-9.1 28	5.036 0.94 7.9-11.3 18	6.4 2.46 6.4-9.1 24	4.47 0.71 7.6-11.3 15	5.59 1.65 8.2-9.1 19
600 0.2834	Face vel P <sub>t</sub> mm H <sub>2</sub> O Throw in (M) N.C			8.75 3.3 8.5-12.2 36	12.88 10.52 7.0-10.0 39	7.27 2.06 8.5-12.2 30	9.84 6.45 7.0-10.0 35	6.04 1.35 8.5-12.2 25	7.68 3.58 7.0-10.0 31	5.37 1.04 8.5-12.2 19	6.72 2.36 6.7-10.1 24
700 0.3307	Face vel P <sub>t</sub> mm H <sub>2</sub> O Throw in (M) N.C					8.48 2.82 9.1-13.1 36	11.48 8.76 7.6-10.9 42	7.05 1.83 9.1-13.1 32	8.96 4.83 7.6-11.0 37	6.26 1.40 9.1-13.1 25	7.84 3.25 7.6-10.9 31
800 0.3778	Face vel P <sub>t</sub> mm H <sub>2</sub> O Throw in (M) N.C							8.05 2.41 9.8-14.0 36	10.24 6.35 8.2-11.9 41	7.16 1.83 9.8-13.7 33	8.95 4.22 8.2-11.9 37
900 0.425	Face vel P <sub>t</sub> mm H <sub>2</sub> O Throw in (M) N.C							9.06 3.05 10.0-14.6 40	11.52 8.0 8.5-12.5 45	8.05 2.31 10.0-14.6 36	10.07 5.3 8.4-12.5 41

- Face velocity is measured in m/sec.
- Total pressure loss is in mm of H<sub>2</sub>O & Area factor in square meter.
- Throw (meters) is measured for a terminal velocity of 0.5 and 0.25 m/sec.
- NC based on a room attenuation of 10 dB.



air master

# Supply air grilles and registers

Rating with 0° and 45° deflection

► Models: ASG-H, ASG-V, ASR-H, ASR-V

**Table 2.1 (Cont.) Air flow data**

CFM M³/sec	Listed Size in mm x mm	350 x 350 400 x 300 500 x 250 600 x 200 900 x 150		400 x 400 500 x 300 600 x 250 750 x 200		500 x 350 600 x 300 700 x 250 900 x 200 1200 x 150		450 x 450 500 x 400 800 x 250 1000 x 200	
		Area factor Deflection	0.0633 0°	0.0529 45°	0.0827 0°	0.072 45°	0.0962 0°	0.0853 45°	0.1069 0°
500 0.2362	Face vel P <sub>t</sub> mm H <sub>2</sub> O Throw in (M) N.C	3.73 0.48 7.3-10.9 <15	4.47 1.02 5.8-9.1 16	2.86 0.28 6.7-10.7 <15	3.28 0.45 5.5-9.1 <15	2.46 0.20 9.5-10.4 <15	2.77 0.31 5.2-9.1 <15	2.21 0.15 6.1-10.1 <15	2.43 0.23 4.9-8.8 <15
600 0.2834	Face vel P <sub>t</sub> mm H <sub>2</sub> O Throw in (M) N.C	4.47 0.71 8.2-11.9 16	5.36 1.45 6.4-10.1 20	3.43 0.41 7.6-11.6 <15	3.94 0.63 6.4-10.1 18	2.95 0.31 7.3-11.3 <15	3.32 0.43 6.1-10.1 15	2.65 0.23 7.0-10.7 <15	2.92 0.31 6.1-9.8 <15
700 0.3307	Face vel P <sub>t</sub> mm H <sub>2</sub> O Throw in (M) N.C	5.22 0.96 8.8-12.8 22	6.25 1.98 7.3-10.9 26	4.0 0.56 8.5-12.5 19	4.59 0.86 7.0-11.0 23	3.44 0.41 8.5-12.2 16	3.88 0.56 7.0-10.9 20	3.09 0.31 8.2-11.9 15	3.4 0.43 6.7-10.7 19
800 0.3778	Face vel P <sub>t</sub> mm H <sub>2</sub> O Throw in (M) N.C	5.97 1.27 9.8-13.4 30	7.14 2.59 8.2-11.9 32	4.57 0.71 9.5-13.1 26	5.25 1.14 7.9-10.6 28	3.93 0.53 9.5-13.1 21	4.43 0.74 7.9-11.6 25	3.53 0.38 9.1-12.5 20	3.89 0.56 7.6-11.3 24
900 0.425	Face vel P <sub>t</sub> mm H <sub>2</sub> O Throw in (M) N.C	6.71 1.60 10.1-14.6 33	8.03 3.25 8.5-12.5 36	5.14 0.91 10.1-14.3 30	5.9 1.45 8.5-12.2 33	4.42 0.68 10.1-14.0 25	4.98 0.94 8.5-12.2 30	3.98 0.48 9.8-13.7 24	4.38 0.71 8.2-12.2 29
1000 0.472	Face vel P <sub>t</sub> mm H <sub>2</sub> O Throw in (M) N.C	7.44 1.98 10.7-15 37	8.92 4.01 9.1-13 40	5.69 1.11 10.4-15 34	6.55 1.78 9.1-13.1 36	4.92 0.84 10.4-14.6 30	5.55 1.17 9.1-13.1 33	4.45 0.61 10.1-14.3 29	4.86 0.86 9.2-13.1 32
1100 0.519	Face vel P <sub>t</sub> mm H <sub>2</sub> O Throw in (M) N.C	8.18 2.39 10.9-16 40	9.81 4.88 9.8-14 45	6.25 1.35 10.7-15 36	7.21 2.16 9.8-14 40	5.41 1.02 10.7-15.0 33	6.11 1.42 9.8-14 36	4.89 0.74 10.4-14.9 32	5.35 1.07 9.8-14 35
1200 0.567	Face vel P <sub>t</sub> mm H <sub>2</sub> O Throw in (M) N.C			6.83 1.60 11.3-16 38	7.87 2.54 10.4-15 43	5.91 1.22 11.3-15.9 36	6.67 1.68 10.4-14.9 40	5.35 1.0 11-15.2 35	5.84 1.24 10-14.8 39
1400 0.661	Face vel P <sub>t</sub> mm H <sub>2</sub> O Throw in (M) N.C			7.96 2.18 12.2-17 44	9.18 3.51 11-15.5 49	6.88 1.65 12.2-16.8 41	7.77 2.28 10.9-15.2 44	6.23 1.19 11.6-16.2 40	6.81 1.73 10.4-15 43

- Face velocity is measured in m/sec.
- Total pressure loss is in mm of H<sub>2</sub>O & Area factor in square meter.
- Throw (meters) is measured for a terminal velocity of 0.5 and 0.25 m/sec.
- NC based on a room attenuation of 10 dB.



air master

# Supply air grilles and registers

Rating with 0° and 45° deflection

Models: ASG-H, ASG-V, ASR-H, ASR-V

**Table 2.1 (Cont.) Air flow data**

CFM M <sup>3</sup> /sec	Listed Size in mm x mm	600 x 400 900 x 250 800 x 300 1200 x 200		800 x 350 900 x 300 1100 x 250 1400 x 200		600 x 600 900 x 400 1000 x 350 1200 x 300		750 x 600 900 x 500 1000 x 450 1500 x 300 1200 x 375		800 x 750 900 x 700 1000 x 600 1200 x 500	
		Area factor	Deflection	0°	45°	0°	45°	0°	45°	0°	45°
1100 0.519	Face vel P <sub>t</sub> mm H <sub>2</sub> O Throw in (M) N.C	3.84 0.64 9.8-14.3 30	5.19 0.98 9.2-13.2 33	3.20 0.59 9.2-13.6 28	4.48 0.84 8.6-12.8 29	2.4 0.52 8.8-13.0 25	3.2 0.76 8.1-11.3 27	1.92 0.42 7.0-9.1 20	2.4 0.62 6.2-8.3 24		
1200 0.567	Face vel P <sub>t</sub> mm H <sub>2</sub> O Throw in (M) N.C	4.19 0.87 10.3-14.8 32	5.67 1.09 9.8-14.0 35	3.5 0.69 9.7-14.3 30	4.89 0.92 9.1-13.2 32	2.63 0.58 9.3-13.8 27	3.5 0.81 8.4-11.9 29	2.1 0.48 7.5-10.8 24	2.63 0.71 6.8-9.4 26	1.6 0.38 6.3-9.2 20	1.97 0.51 5.7-8.1 22
1400 0.661	Face vel P <sub>t</sub> mm H <sub>2</sub> O Throw in (M) N.C	4.89 0.93 10.8-15.4 35	6.61 1.51 10.2-14.6 38	4.08 0.76 10.1-15.0 33	5.7 1.21 9.7-13.8 35	3.06 0.63 9.7-14.3 30	4.08 0.98 8.8-11.3 32	2.45 0.51 8.1-11.3 27	3.06 0.79 7.3-10.1 29	1.87 0.43 6.8-10.1 23	2.29 0.58 6.1-8.8 25
1600 0.756	Face vel P <sub>t</sub> mm H <sub>2</sub> O Throw in (M) N.C	5.59 1.03 11.5-16.9 38	7.56 1.82 10.8-15.1 40	4.67 0.84 10.6-15.4 36	6.52 1.43 10.1-14.5 37	3.5 0.71 10.1-14.8 33	4.82 1.12 9.3-12.1 34	2.8 0.63 8.8-12.1 29	3.5 0.91 7.9-10.7 31	2.13 0.51 7.3-10.9 25	2.63 0.64 6.7-9.2 28
1800 0.85	Face vel P <sub>t</sub> mm H <sub>2</sub> O Throw in (M) N.C	6.29 1.32 12.6-18.2 41	8.5 2.24 11.4-17.3 44	5.25 0.97 11.8-16.7 39	7.33 1.73 10.7-15.3 41	3.94 0.82 10.9-16.1 36	5.32 1.34 9.8-14.1 37	3.15 0.72 10.1-14.2 31	3.94 1.13 8.2-12.2 33	2.4 0.58 7.9-11.6 28	2.95 0.78 7.1-9.8 31
2000 0.945	Face vel P <sub>t</sub> mm H <sub>2</sub> O Throw in (M) N.C	6.99 1.61 13.8-19.7 44	9.78 2.53 12.4-18.6 47	5.83 1.03 13.2-18.1 41	8.15 1.92 11.6-16.5 43	4.38 0.88 12.1-17.3 39	5.83 1.52 10.3-14.8 41	3.5 0.78 10.7-15.1 33	4.38 1.23 8.8-13.1 36	2.7 0.61 8.2-11.8 28	3.28 0.83 7.4-10.4 32
2200 1.039	Face vel P <sub>t</sub> mm H <sub>2</sub> O Throw in (M) N.C			6.41 1.16 14.3-19.5 44	8.96 2.42 12.4-17.7 47	4.81 0.95 12.8-18.1 41	6.41 1.82 10.9-15.7 44	3.85 0.83 11.2-16.4 35	4.81 1.45 9.3-13.8 39	2.94 0.72 8.9-13.0 30	3.61 0.93 8.1-11.3 33
2400 1.134	Face vel P <sub>t</sub> mm H <sub>2</sub> O Throw in (M) N.C					5.25 1.13 13.7-19.2 43	7.0 2.04 11.4-16.4 46	4.2 0.93 12.2-17.3 37	5.25 1.63 9.9-14.7 42	3.2 0.81 9.5-13.8 32	3.94 1.03 8.7-12.1 35
2600 1.228	Face vel P <sub>t</sub> mm H <sub>2</sub> O Throw in (M) N.C					5.69 1.43 14.4-21.3 45	7.58 2.43 12.1-17.6 48	4.55 1.07 13.1-18.4 40	5.69 1.93 10.7-15.4 44	3.47 0.92 10.7-15.7 33	4.26 1.32 9.3-13.2 37

- Face velocity is measured in m/sec.
- Total pressure loss is in mm of H<sub>2</sub>O & Area factor in square meter.
- Throw (meters) is measured for a terminal velocity of 0.5 and 0.25 m/sec.
- NC based on a room attenuation of 10 dB.



air master

# Return air grille

– Fixed horizontal blades at 45°

→ Models: ARG-H

### Table 2.2 Air flow data

Listed size in mm x mm	Face vel m/sec.	1.5	2.0	2.5	3.0	3.5	4.0	4.5	5.0
	P <sub>s</sub> mm H <sub>2</sub> O	0.91	1.63	2.54	3.68	4.97	6.5	8.33	10.16
250x100 / 200x125 150x150	CFM	60	80	100	120	140	160	180	200
	M <sup>3</sup> /sec.	0.0283	0.0378	0.0472	0.0567	0.0661	0.0756	0.085	0.0945
	NC	<15	16	24	27	31	36	41	46
200x150 / 250x125 300x100	CFM	81	108	135	162	189	216	243	270
	M <sup>3</sup> /sec.	0.0383	0.051	0.0638	0.765	0.0893	0.102	0.1148	0.1275
	NC	<15	16	24	27	31	36	41	46
250x150 / 300x125 400x100	CFM	102	136	170	204	238	272	306	340
	M <sup>3</sup> /sec.	0.0482	0.0642	0.0803	0.0964	0.1124	0.1285	0.1445	0.1606
	NC	<15	15	24	27	31	36	41	46
300x150 / 350x125 450x100	CFM	120	160	200	240	280	320	360	400
	M <sup>3</sup> /sec.	0.0567	0.0756	0.0945	0.1134	0.1322	0.1512	0.17	0.1889
	NC	<15	15	25	28	31	36	41	47
250x200 / 350x150 400x125 / 500x100	CFM	141	188	235	282	329	376	423	470
	M <sup>3</sup> /sec.	0.0666	0.088	0.1109	0.1332	0.1554	0.178	0.199	0.222
	NC	<15	16	24	27	31	35	40	47
250x250 / 300x200 400x150 / 500x125 600x100	CFM	162	216	270	324	378	432	486	540
	M <sup>3</sup> /sec.	0.0765	0.102	0.1275	0.153	0.1785	0.204	0.2295	0.255
	NC	<15	16	24	27	31	35	42	47
300x250 / 450x150 500x150 / 600x125 750x100	CFM	180	270	300	360	420	480	540	600
	M <sup>3</sup> /sec.	0.085	0.1133	0.142	0.17	0.198	0.2267	0.255	0.2833
	NC	<15	17	23	27	31	35	40	46
300x300 / 350x250 450x200 / 600x150	CFM	240	320	400	480	560	640	720	800
	M <sup>3</sup> /sec.	0.1133	0.151	0.1889	0.2267	0.2645	0.302	0.3401	0.3778
	NC	<15	18	23	27	31	35	40	47
350x300 / 400x250 500x200 / 750x150	CFM	300	400	500	600	700	800	900	1000
	M <sup>3</sup> /sec.	0.1416	0.1889	0.236	0.283	0.331	0.3778	0.425	0.4723
	NC	<15	19	23	27	32	36	40	48
350x350 / 400x300 500x250 / 600x200 900x150	CFM	360	480	600	720	840	960	1080	1200
	M <sup>3</sup> /sec.	0.17	0.2267	0.283	0.34	0.3967	0.453	0.51	0.5667
	NC	<15	21	24	27	32	36	40	48
400x350 / 550x250 700x200	CFM	420	560	700	840	980	1120	1260	1400
	M <sup>3</sup> /sec.	0.198	0.264	0.331	0.397	0.463	0.529	0.595	0.661
	NC	<15	21	24	28	33	37	41	49
400x400 / 500x300 600x250 / 800x200	CFM	480	640	800	960	1120	1280	1440	1600
	M <sup>3</sup> /sec.	0.2267	0.3023	0.3778	0.453	0.529	0.6046	0.68	0.7556
	NC	16	22	25	29	33	38	42	49
500x350/600x300 700x250/900x200 1000x150	CFM	540	720	900	1080	1260	1440	1620	1800
	M <sup>3</sup> /sec.	0.255	0.3401	0.4251	0.51	0.51	0.6801	0.765	0.85
	NC	17	22	25	29	34	42	43	50
450x450 / 500x400 750x250 1000x200	CFM	600	800	1000	1200	1400	1600	1800	2000
	M <sup>3</sup> /sec.	0.2834	0.3778	0.4723	0.5668	0.6612	0.7556	0.85	0.9446
	NC	18	23	26	30	35	43	41	50
500x500 / 550x450 750x300 / 900x250 1000x200	CFM	660	880	1100	1320	1540	1760	1980	2200
	M <sup>3</sup> /sec.	0.3117	0.4156	0.5195	0.6234	0.7273	0.8313	0.935	1.039
	NC	18	23	27	31	36	40	44	52

- Face velocity is measured in m/sec.
- P<sub>s</sub>: static pressure loss in mm H<sub>2</sub>O
- NC based on a room attenuation of 10 dB.



air master

# Return air grilles and registers

Rating with 0° deflection

Models: ARG-V, ARG-HA, ARR-V, ARR-HA

## Table 2.3 Air flow data

Listed size in mm x mm	Face vel m/sec.	2.5	3.0	3.5	4.0	4.5	5.00	5.50	6.00
	P <sub>s</sub> mm H <sub>2</sub> O	1.7	2.46	3.35	4.37	5.59	6.86	8.38	9.9
250x100 / 200x125 150x150	CFM	150	180	210	240	270	300	330	360
	M <sup>3</sup> /sec.	0.071	0.085	0.099	0.113	0.127	0.142	0.156	0.17
	NC	<15	19	22	25	29	33	36	38
200x150 / 250x125 300x100	CFM	180	210	240	280	320	350	390	420
	M <sup>3</sup> /sec.	0.085	0.099	0.113	0.132	0.151	0.165	0.184	0.198
	NC	<15	18	22	26	29	33	35	37
250x150 / 300x125 400x100	CFM	220	260	310	350	400	440	490	530
	M <sup>3</sup> /sec.	0.104	0.123	0.146	0.165	0.189	0.208	0.231	0.250
	NC	16	20	25	28	31	35	38	40
300x150 / 350x125 450x100	CFM	240	290	340	390	440	490	540	590
	M <sup>3</sup> /sec.	0.113	0.137	0.161	0.184	0.208	0.231	0.255	0.279
	NC	15	20	24	27	30	34	37	40
250x200 / 350x150 400x125 / 500x100	CFM	270	320	370	420	480	530	590	640
	M <sup>3</sup> /sec.	0.127	0.151	0.165	0.198	0.227	0.25	0.279	0.302
	NC	<15	17	21	24	28	31	35	38
250x250 / 300x200 400x150 / 500x125 600x100	CFM	310	370	430	490	550	610	680	740
	M <sup>3</sup> /sec.	0.146	0.165	0.203	0.231	0.259	0.288	0.321	0.349
	NC	15	19	23	26	30	34	36	39
300x250 / 450x150 500x150 / 600x125 750x100	CFM	360	440	510	580	660	730	810	800
	M <sup>3</sup> /sec.	0.17	0.208	0.241	0.274	0.312	0.345	0.382	0.416
	NC	15	20	24	27	31	34	37	39
300x300 / 350x250 450x200 / 600x150	CFM	420	500	590	670	750	840	930	1020
	M <sup>3</sup> /sec.	0.198	0.236	0.279	0.316	0.354	0.397	0.439	0.482
	NC	<15	15	23	27	30	34	37	40
350x300 / 400x250 500x200 / 750x150	CFM	450	540	630	720	810	900	1000	1090
	M <sup>3</sup> /sec.	0.213	0.255	0.297	0.34	0.382	0.425	0.472	0.514
	NC	<15	16	21	25	29	33	37	40
350x350 / 400x300 500x250 / 600x200 900x150	CFM	510	620	720	820	930	1030	1140	1240
	M <sup>3</sup> /sec.	0.241	0.293	0.340	0.387	0.439	0.486	0.538	0.586
	NC	15	20	24	29	32	37	40	43
400x400 / 500x300 600x250 / 800x200	CFM	580	700	820	940	1050	1170	1290	1400
	M <sup>3</sup> /sec.	0.274	0.331	0.387	0.444	0.496	0.553	0.609	0.661
	NC	15	20	25	30	34	38	41	44
500x350/600x300 700x250/900x200 1000x150	CFM	660	800	930	1060	1200	1330	1470	1600
	M <sup>3</sup> /sec.	0.312	0.378	0.439	0.501	0.567	0.628	0.694	0.756
	NC	16	22	26	32	35	39	42	45
450x450 / 500x400 750x250 1000x200	CFM	700	840	980	1120	1270	1400	1550	1690
	M <sup>3</sup> /sec.	0.331	0.397	0.463	0.529	0.599	0.661	0.732	0.798
	NC	16	21	25	30	33	35	39	43
500x500 / 550x450 750x300 / 900x250 1000x200	CFM	800	970	1130	1280	1440	1600	1770	1930
	M <sup>3</sup> /sec.	0.378	0.458	0.533	0.605	0.68	0.756	0.836	0.912
	NC	18	23	27	33	38	40	43	45

- Face velocity is measured in m/sec.
- P<sub>s</sub>: static pressure loss in mm H<sub>2</sub>O
- NC based on a room attenuation of 10 dB.



air master

# Return air grilles and registers

Rating with 45° deflection

Models: ARG-V, ARG-HA, ARR-V, ARR-HA

**Table 2.3 (cont.) Air flow data**

Listed size in mm x mm	Face vel m/sec.	2.75	3.25	4.0	4.5	5.0	5.5	6.0	6.5
	P <sub>s</sub> mm H <sub>2</sub> O	2.16	3.05	4.32	5.59	7.11	8.89	10.92	12.95
250x100 / 200x125 150x150	CFM	150	180	210	240	270	300	330	360
	M <sup>3</sup> /sec.	0.071	0.085	0.099	0.113	0.127	0.142	0.156	0.17
	NC	18	22	25	28	32	36	39	41
200x150 / 250x125 300x100	CFM	180	210	240	280	320	350	390	420
	M <sup>3</sup> /sec.	0.085	0.099	0.113	0.132	0.151	0.165	0.184	0.198
	NC	17	21	25	29	32	36	38	40
250x150 / 300x125 400x100	CFM	220	260	310	350	400	440	490	530
	M <sup>3</sup> /sec.	0.104	0.123	0.146	0.165	0.189	0.208	0.231	0.250
	NC	19	23	28	31	34	38	41	43
300x150 / 350x125 450x100	CFM	240	290	340	390	440	490	540	590
	M <sup>3</sup> /sec.	0.113	0.137	0.161	0.184	0.208	0.231	0.255	0.279
	NC	18	23	27	30	33	37	40	43
250x200 / 350x150 400x125 / 500x100	CFM	270	320	370	420	480	530	590	640
	M <sup>3</sup> /sec.	0.127	0.151	0.165	0.198	0.227	0.25	0.279	0.302
	NC	16	20	24	27	31	34	38	41
250x250 / 300x200 400x150 / 500x125 600x100	CFM	310	370	430	490	550	610	680	740
	M <sup>3</sup> /sec.	0.146	0.165	0.203	0.231	0.259	0.288	0.321	0.349
	NC	18	22	26	29	33	37	39	42
300x250 / 450x150 500x150 / 600x125 750x100	CFM	360	440	510	580	660	730	810	800
	M <sup>3</sup> /sec.	0.17	0.208	0.241	0.274	0.312	0.345	0.382	0.416
	NC	18	23	27	30	34	37	40	42
300x300 / 350x250 450x200 / 600x150	CFM	420	500	590	670	750	840	930	1020
	M <sup>3</sup> /sec.	0.198	0.236	0.279	0.316	0.354	0.397	0.439	0.482
	NC	<15	18	26	30	33	37	40	43
350x300 / 400x250 500x200 / 750x150	CFM	450	540	630	720	810	900	1000	1090
	M <sup>3</sup> /sec.	0.213	0.255	0.297	0.34	0.382	0.425	0.472	0.514
	NC	15	19	24	28	32	36	40	43
350x350 / 400x300 500x250 / 600x200 900x150	CFM	510	620	720	820	930	1030	1140	1240
	M <sup>3</sup> /sec.	0.241	0.293	0.340	0.387	0.439	0.486	0.538	0.586
	NC	18	23	27	32	35	40	43	46
400x400 / 500x300 600x250 / 800x200	CFM	580	700	820	940	1050	1170	1290	1400
	M <sup>3</sup> /sec.	0.274	0.331	0.387	0.444	0.496	0.553	0.609	0.661
	NC	15	20	25	30	37	41	44	47
500x350/600x300 700x250/900x200 1000x150	CFM	660	800	930	1060	1200	1330	1470	1600
	M <sup>3</sup> /sec.	0.312	0.378	0.439	0.501	0.567	0.628	0.694	0.756
	NC	19	25	29	35	38	42	45	48
450x450 / 500x400 750x250 1000x200	CFM	700	840	980	1120	1270	1400	1550	1690
	M <sup>3</sup> /sec.	0.331	0.397	0.463	0.529	0.599	0.661	0.732	0.798
	NC	19	24	28	33	36	38	42	46
500x500 / 550x450 750x300 / 900x250 1000x200	CFM	800	970	1130	1280	1440	1600	1770	1930
	M <sup>3</sup> /sec.	0.378	0.458	0.533	0.605	0.68	0.756	0.836	0.912
	NC	21	26	30	36	41	43	46	48

- Face velocity is measured in m/sec.
- P<sub>s</sub>: static pressure loss in mm H<sub>2</sub>O
- NC based on a room attenuation of 10 dB.



# Decorative Grilles

Model: AMDG

## Introduction:

The application of AIR MASTER grilles has been extended from the comfort conditioning field to the aesthetic aspects of the environment they are used. AIR MASTER has developed a new generation of grilles, which can be adopted for any professional areas with aesthetic preference.

AIR MASTER decorative grilles are designed for modern interior layouts and guaranteed for an unparalleled beauty and brilliance backed up with perfect technology.

So, eventually it serves the dual purpose of interior decoration and air conditioning on its own. The decorative grilles are manufactured and supplied at affordable prices.

## Construction:

- **Frame:** High quality extruded aluminium profile with 25mm flange width as standard and 12, 30mm flange widths as optional.
- **Core:** Core is made up of aluminium sheet, machined to the desired design patterns required by the customer.
- **Damper frame and blades:** High quality extruded aluminium profiles with black matt finish. Natural aluminium finish as option.



## Description:

- The frame is of high quality extruded aluminium profiled construction with the advantages of corrosion resistance and rigidity.
- The core will be the heart of the decorative grille and it is pressed aluminium sheet 3mm thickness as standard. The required designs are cut by using the most advanced laser technology.
- The decorative grilles are rigidly fixed with opposed blade damper by grippers. Damper blade is operated from the face opening.
- Foam gasket is sealed around the back of the frame as option to avoid air leakage.





air master

**Standard finishes:**

- Natural aluminium finish.
- Powder coated color finish as per RAL color codes.
- Flexibility of finishing available on request.

**Other details:**

- Free area mainly depends on the design pattern of core / grille. The same can be provided on request.
- Fixing methods are same as our normal grilles either by screws or concealed clips.
- These decorative grilles can be fixed on ceilings or wall.

**Decorative Grille Patterns:**

